

Corso di Elettronica Industriale (N. O.)

Prof. Ing. L. Masotti

■ **Libri di testo**

- Jacob Millman, Arvin Grabel:
Microelectronics
Mc Graw Hill, 1981
- Ulrich Tietze, Christoph Schenk:
Electronic circuits - Design and applications
Springer Verlag Heidelberg, 1991
- John G. Kassakian, Martin F. Schlecht, George C. Verghese:
Principles of power electronics
Addison-Wesley Publishing Company, Inc., 1992

Dispositivo a 4 strati

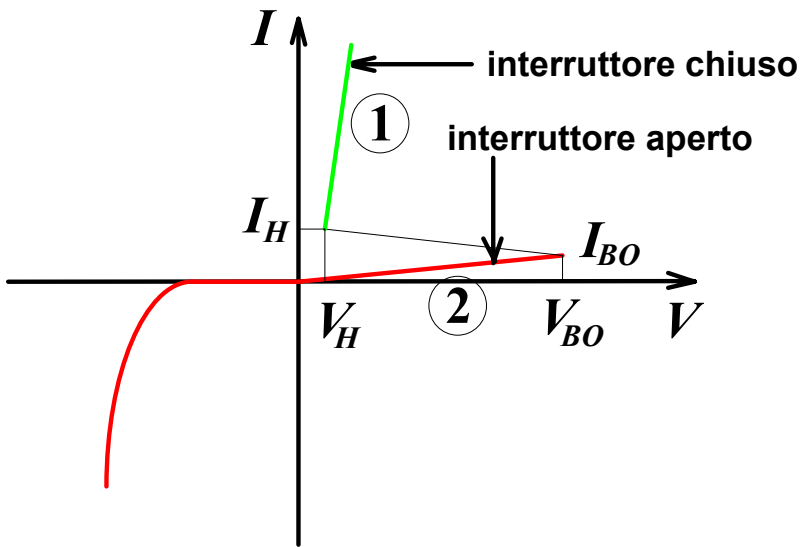
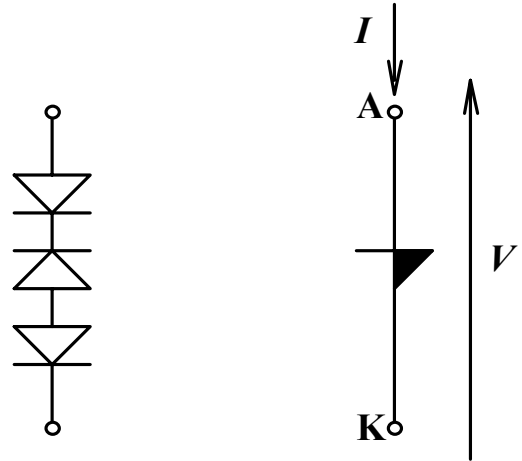
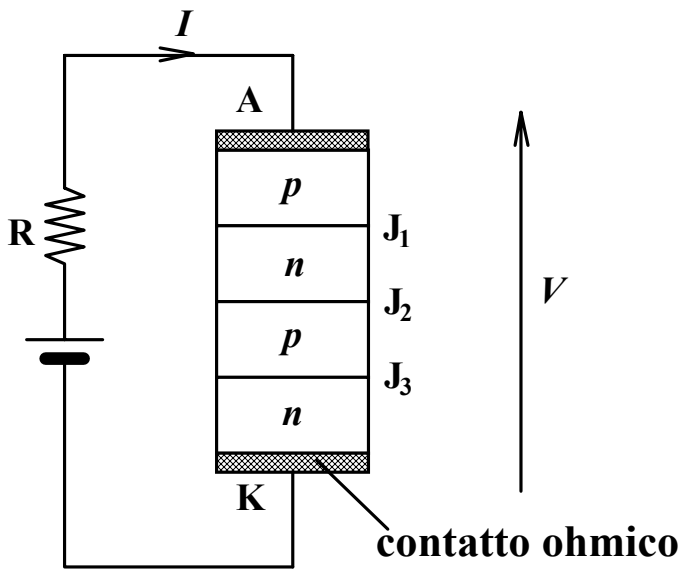

$I_H \cong 10 \div 1000 \text{ mA}$

$V_H \cong 0,5 \div 1 \text{ V}$

$I_{BO} \cong \frac{1}{100} I_H$

$V_{BO} \cong 10 \div 100 \text{ V}$

$r_{d(on)} \cong 1 \div 10 \Omega$

$r_{d(off)} \cong 10 \div 100 \text{ M}\Omega$

Modello equivalente di Shockley

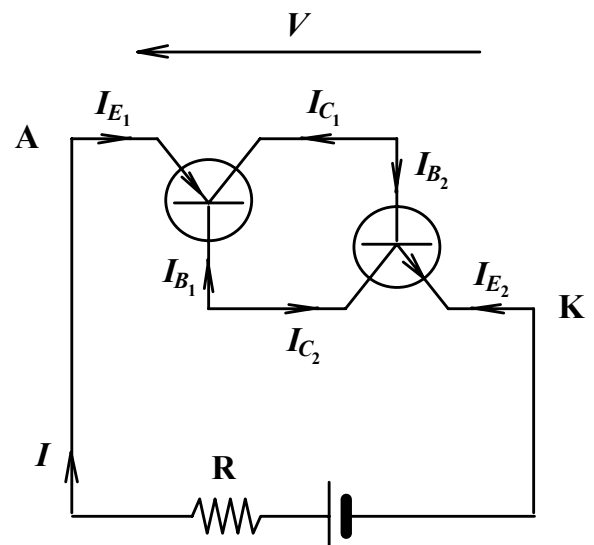
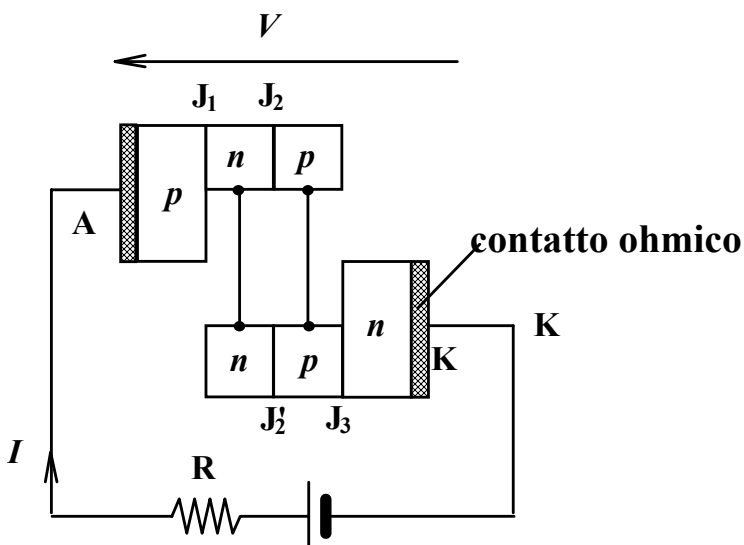

$$I_{E_1} + I_{C_1} + I_{B_1} = 0$$

$$I - \alpha_1 I_{E_1} + I_{C_{0,1}} + \alpha_2 I_{E_2} - I_{C_{0,2}} = 0$$

$$I (1 - \alpha_1 - \alpha_2) + I_{C_{0,1}} - I_{C_{0,2}} = 0$$

$$I = \frac{I_{C_0}}{1 - (\alpha_1 + \alpha_2)}$$

$$\begin{aligned} I_{C_1} &= -\alpha_1 I_{E_1} + I_{C_{0,1}} \\ I_{C_2} &= -\alpha_2 I_{E_2} + I_{C_{0,2}} \end{aligned}$$

$$\begin{aligned} I_{E_1} &= I \\ I_{B_1} &= -I_{C_2} \\ I_{C_1} &= -I_{B_2} \\ I_{E_2} &= -I \end{aligned}$$

$$I_{C_{0,1}} = -I_{C_{0,2}} = \frac{-I_{C_0}}{2}$$

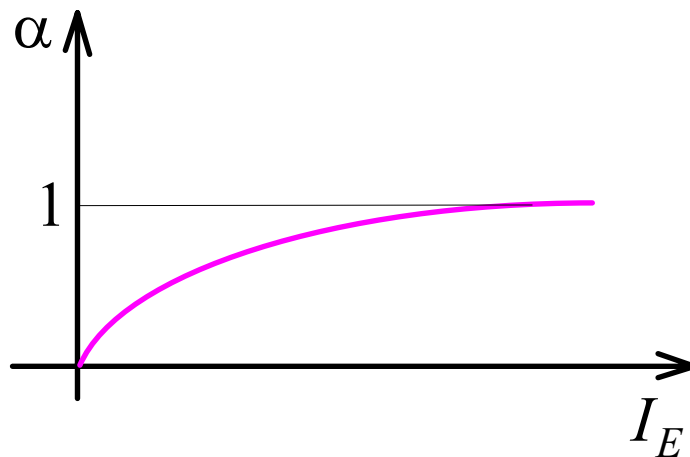

$$V_H = 2V_{BE,sat} - V_{BC} - V_{bulk}$$

è non sensibile alla T

Tempo di accensione : $t_{turn-on}$ (trascurabile)

Tempo di spegnimento : $t_{turn-off}$ $\begin{cases} 1 \div 15 \mu s (\text{bassa potenza}) \\ 15 \div 150 \mu s (\text{elevata potenza}) \end{cases}$

Diac

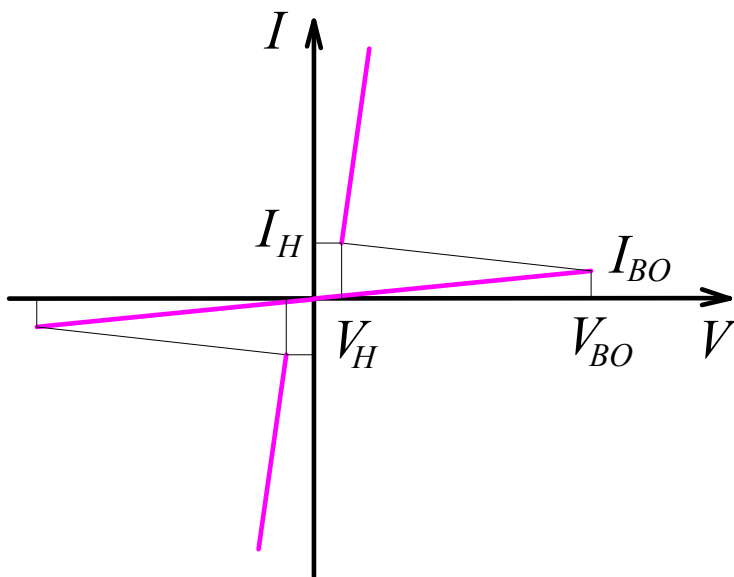
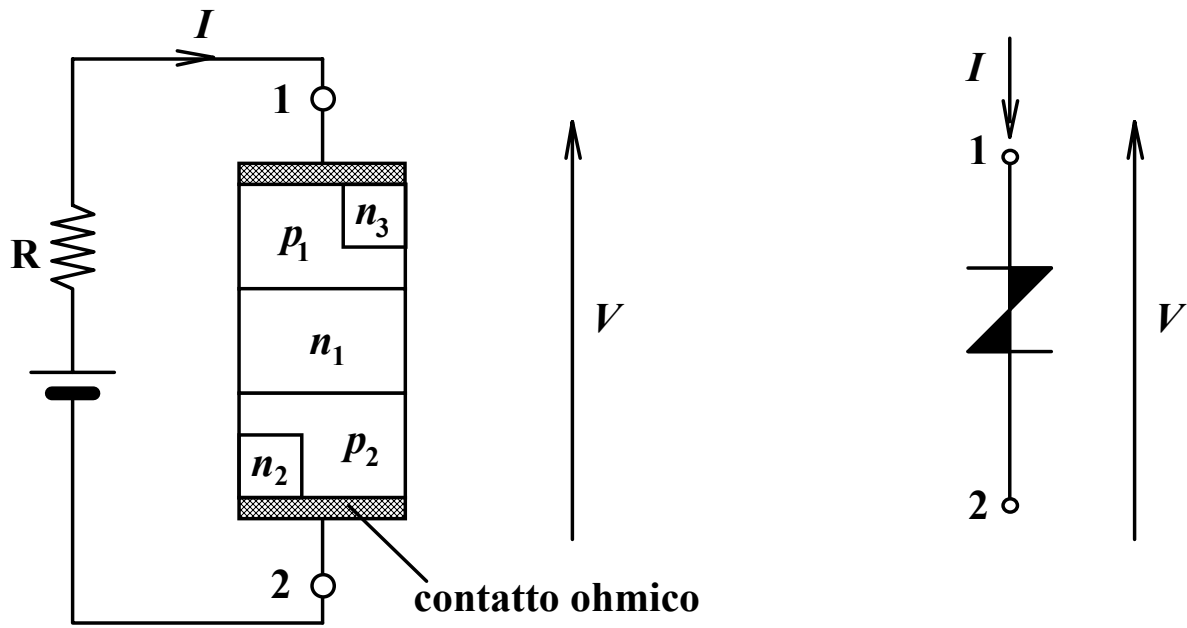

$$|V_{bk}| > |V_{BO}|$$

Oscillatore a rilassamento

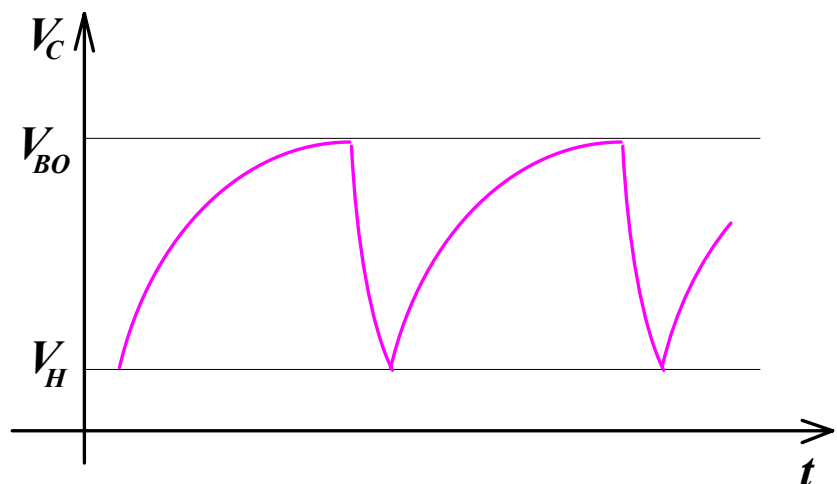
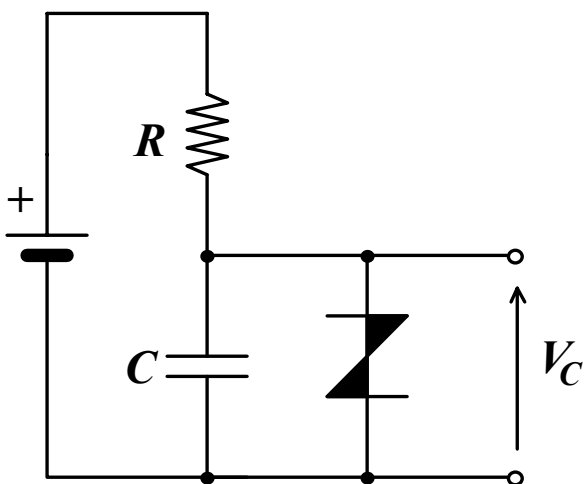

SCR = Silicon Controlled Rectifier

SCS = Silicon Controlled Switch

LAS = Light Activated Switch

GTO = Gate Thyristor Operator (Gate Turn off operating)



Thyratron

Tiristore a controllo di anodo

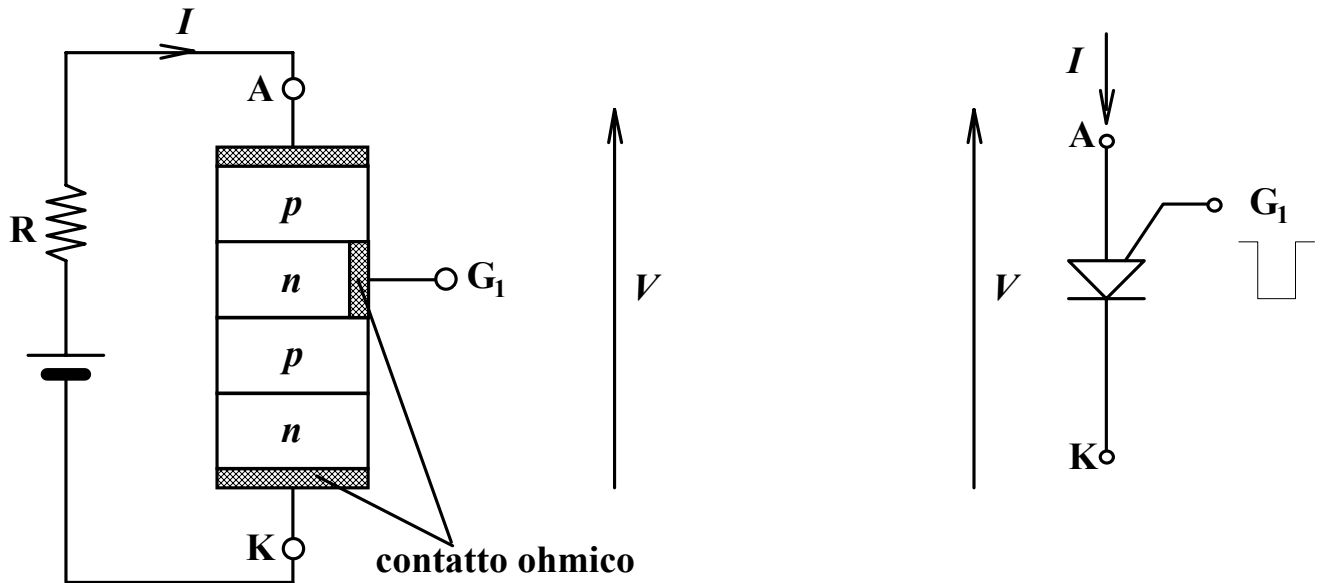

Tiristore a controllo di catodo

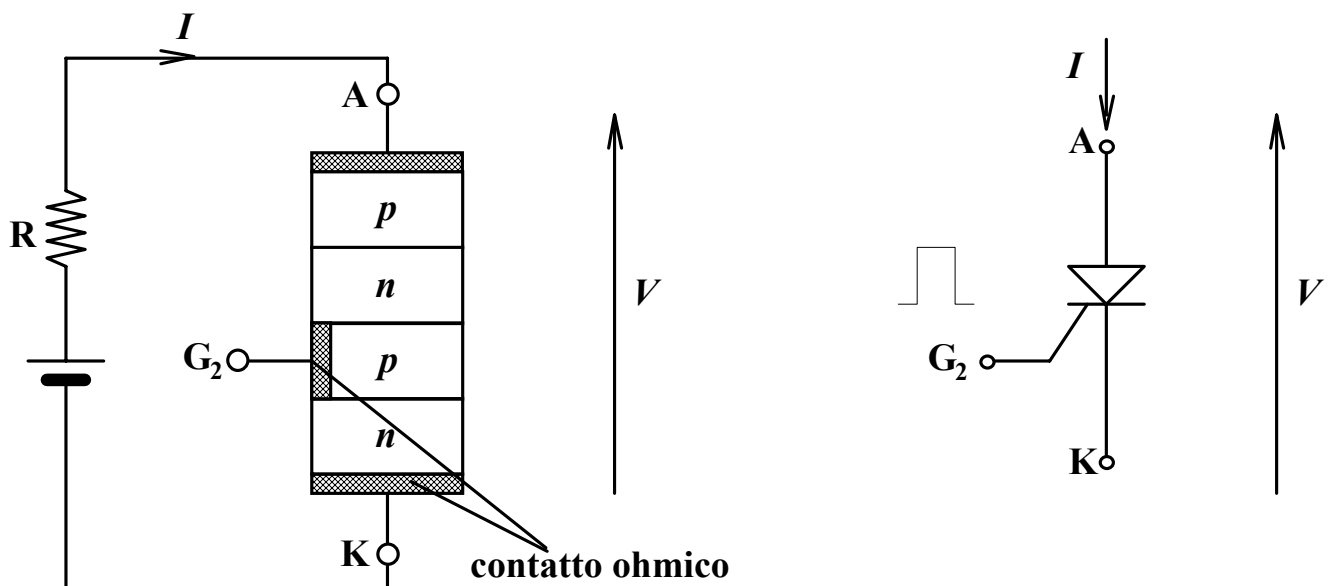

Modello equivalente

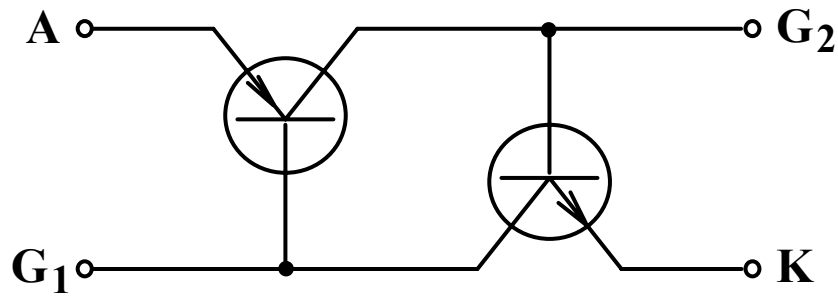

$$I_B \uparrow \Rightarrow I_E \uparrow \Rightarrow \alpha \uparrow$$

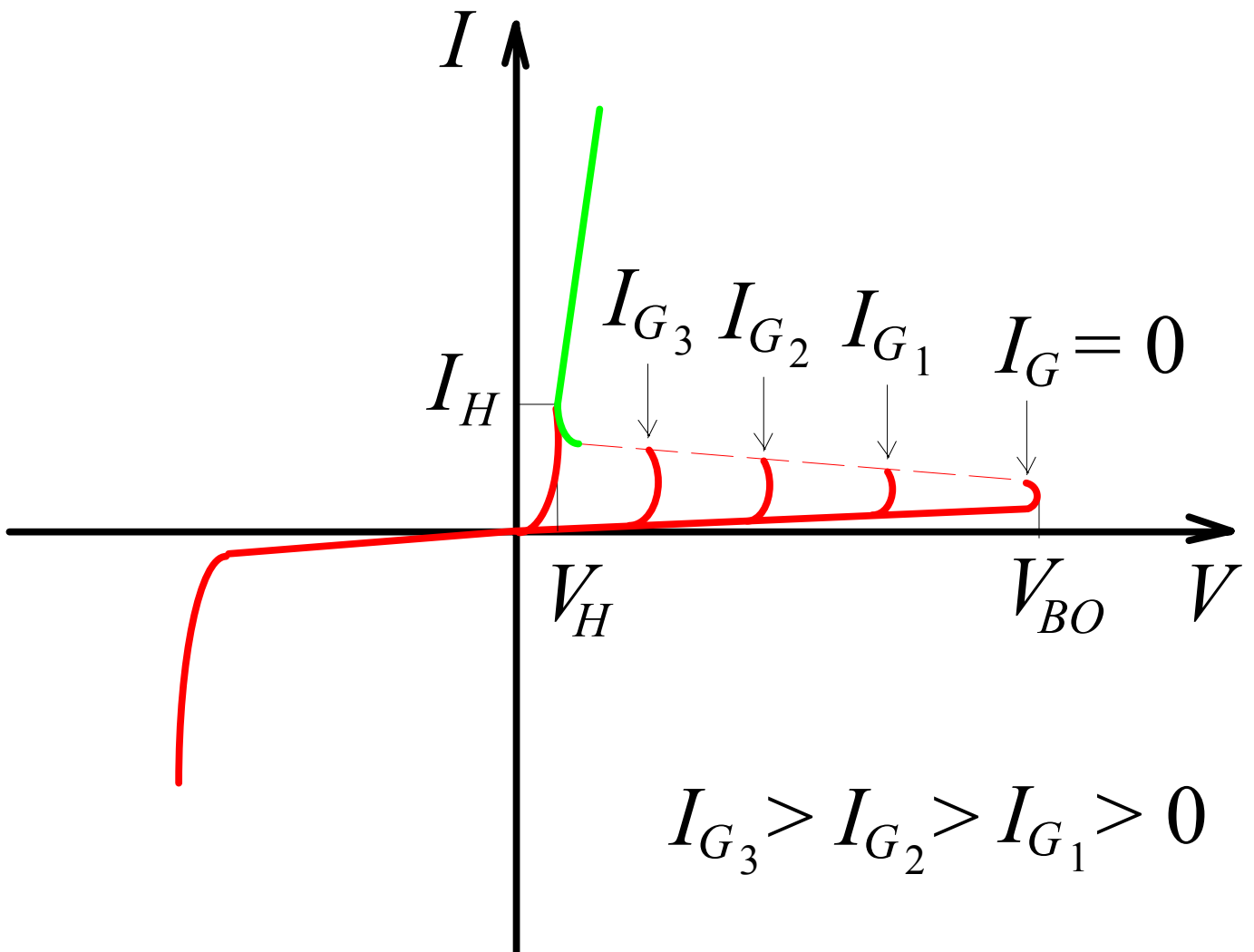

Applicazione: dimmer

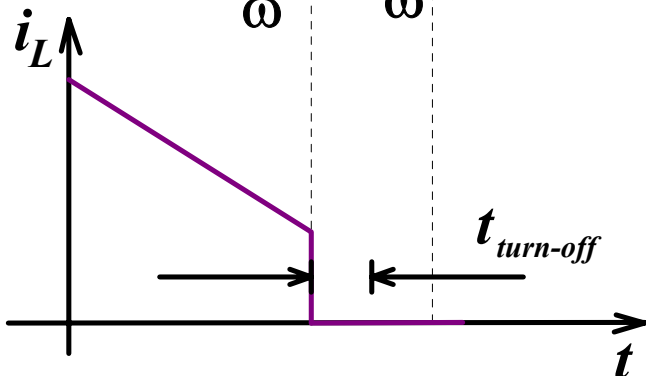
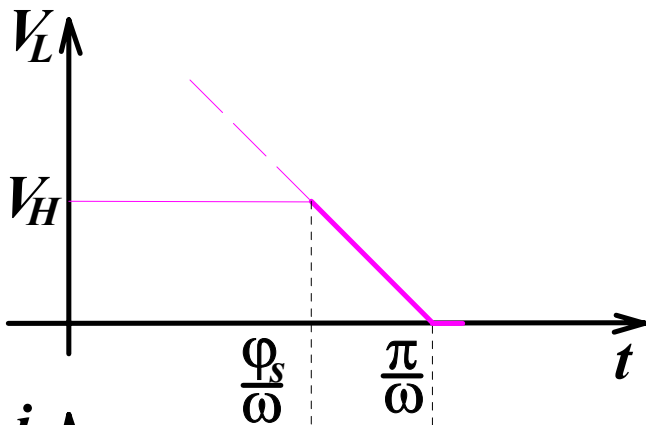
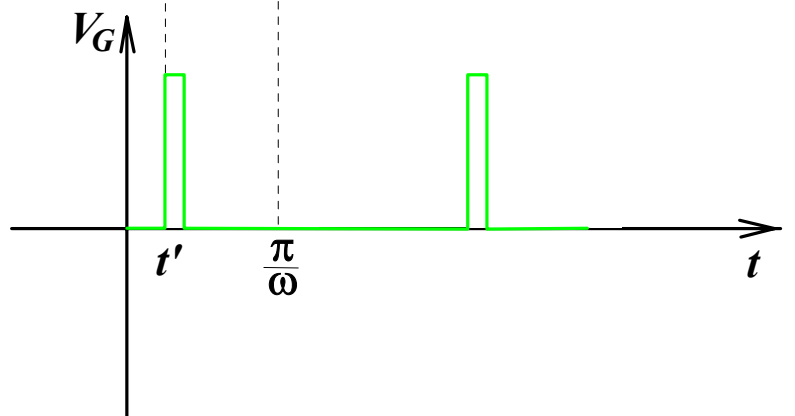
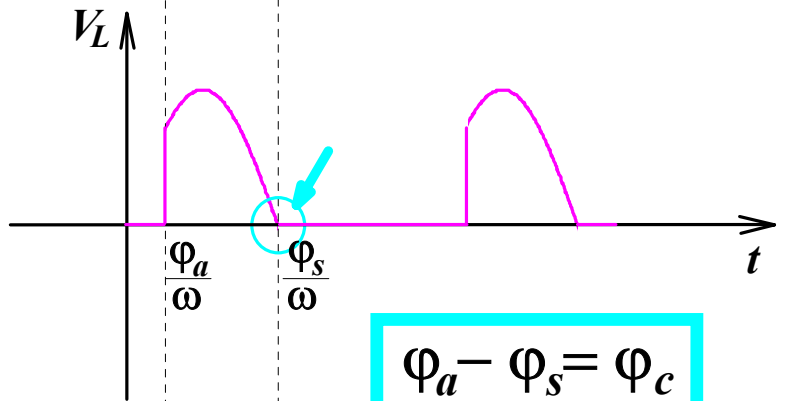
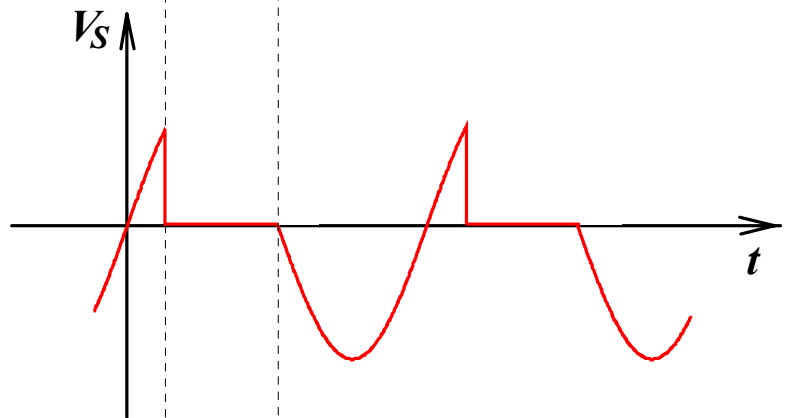
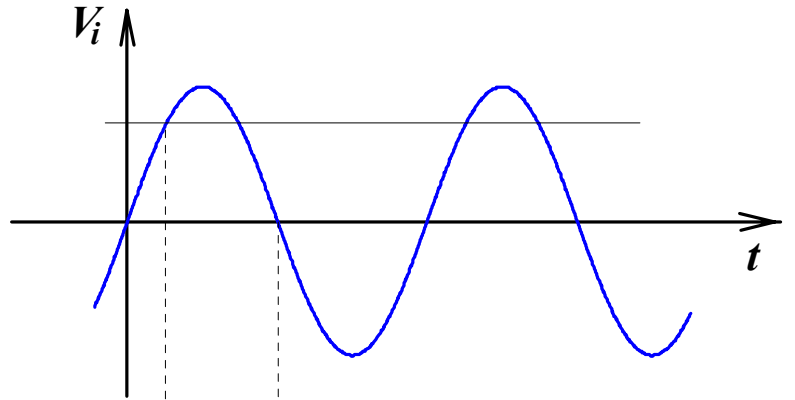
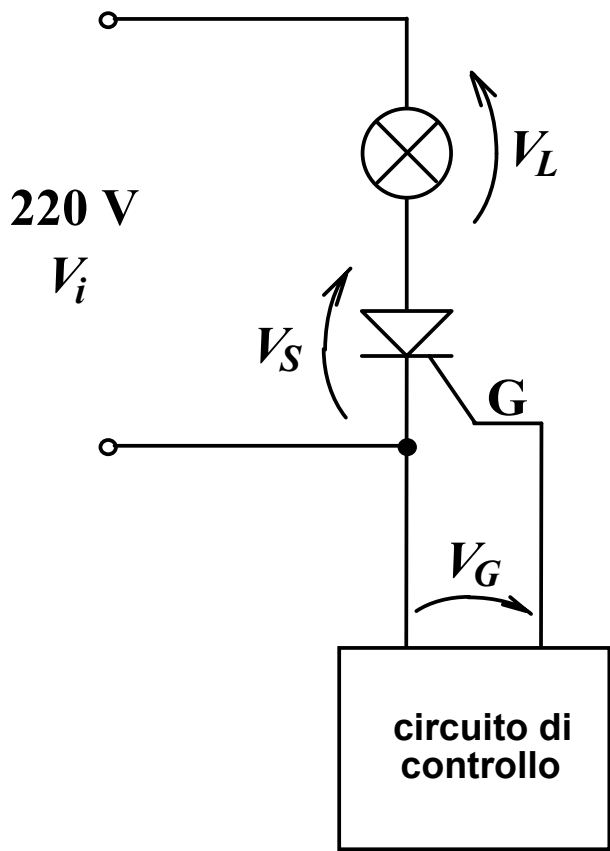

Problemi legati al tempo di turn-off

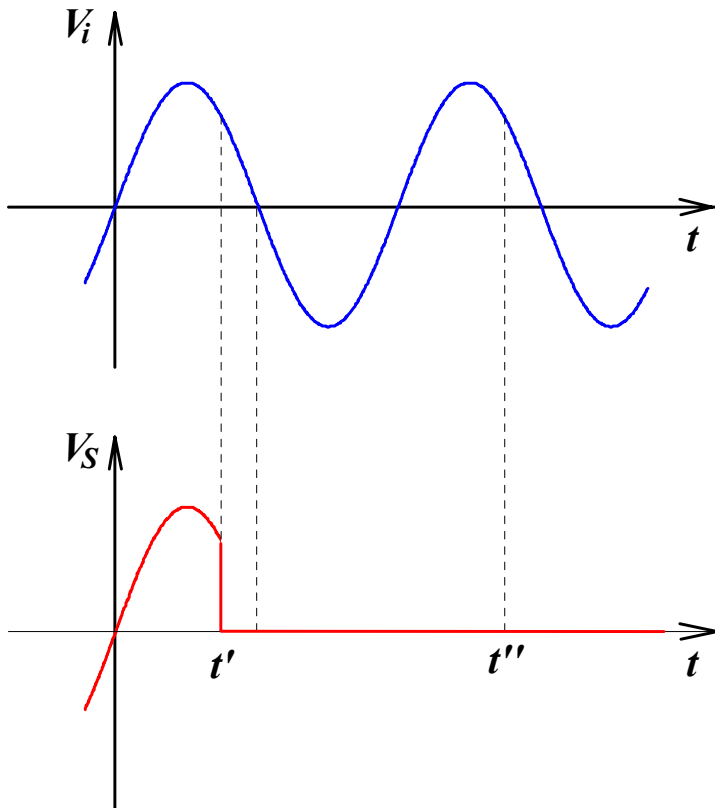

$$f_{\max} < \frac{1}{2t_{\text{turn-off}}}$$

Parzializzazione di conduzione sul carico

$$\bar{V}_L = \frac{1}{2\pi} \int_{\varphi_a}^{\varphi_s} (V_m \text{sen } \omega t - V_H) d\omega t = \frac{V_m}{2\pi} \int_{\varphi_a}^{\varphi_s} \left(\text{sen } \omega t - \frac{V_H}{V_m} \right) d\omega t$$

$$\begin{aligned} &\Downarrow \\ &\frac{V_H}{V_m} \cong 0 \\ &\Downarrow \end{aligned}$$

$$\bar{V}_L \cong \frac{V_m}{2\pi} \int_{\varphi_a}^{\varphi_s} \text{sen } \omega t d\omega t = \frac{V_m}{2\pi} [-\cos \omega t]_{\varphi_a}^{\varphi_s} = \frac{V_m}{2\pi} (1 + \cos \varphi_a)$$

Problematiche legate all'uso di scr

**capacità di transizione e problemi causati all'accensione del circuito
e per via di disturbi impulsivi presenti in rete**

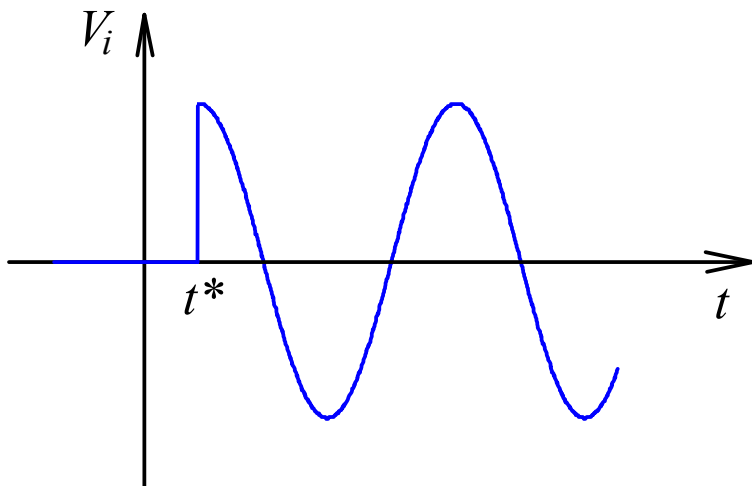
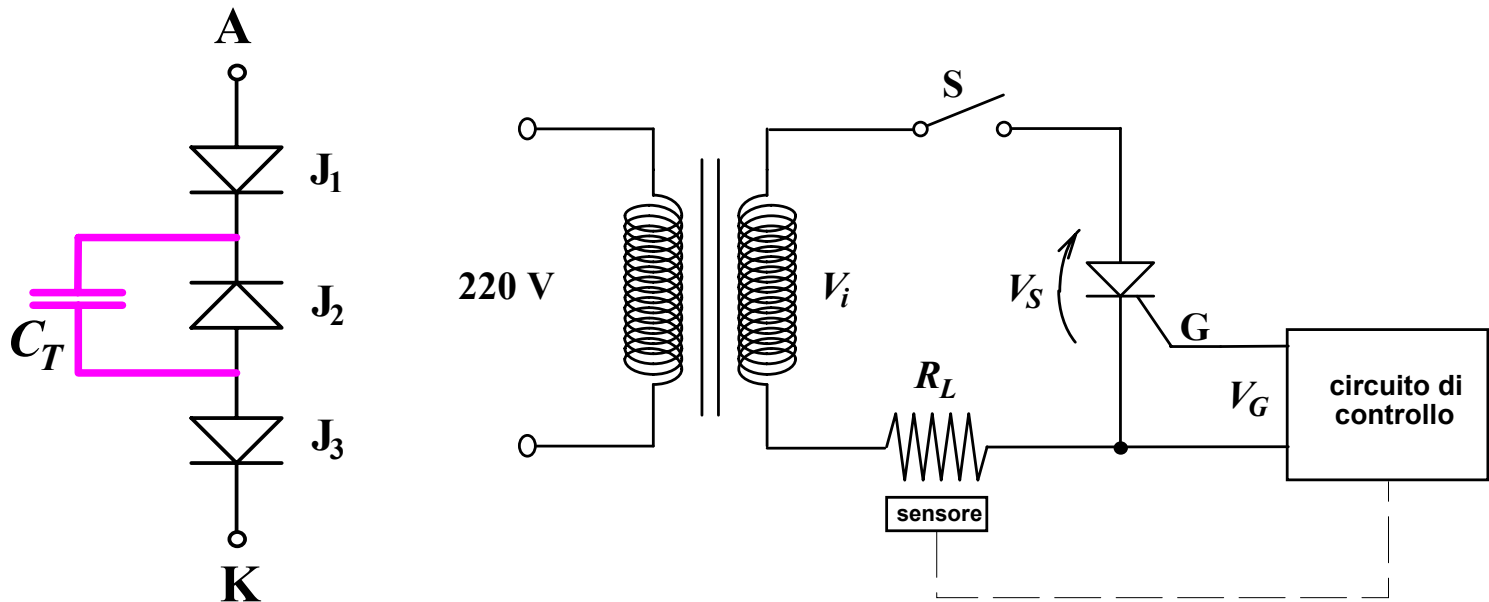

$$i = C_T \frac{dV_{AK}}{dt}$$

$$\frac{dV_{AK}}{dt} < 100 \frac{\mu V}{s}$$

Deve inoltre essere limitata anche la $\frac{di}{dt}$ altrimenti si possono instaurare punti caldi oltre che cadute di potenziale trasversali

Triac

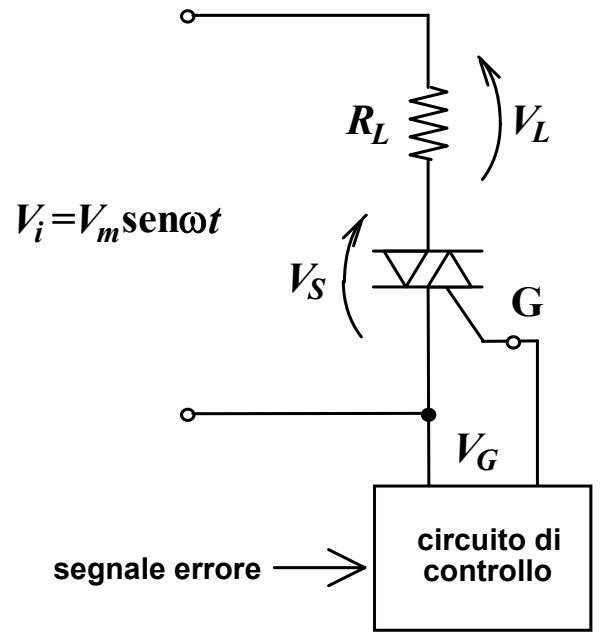
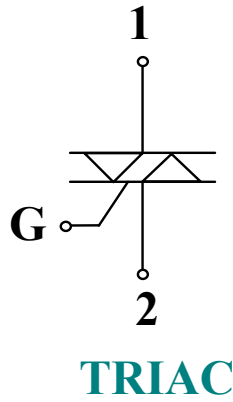
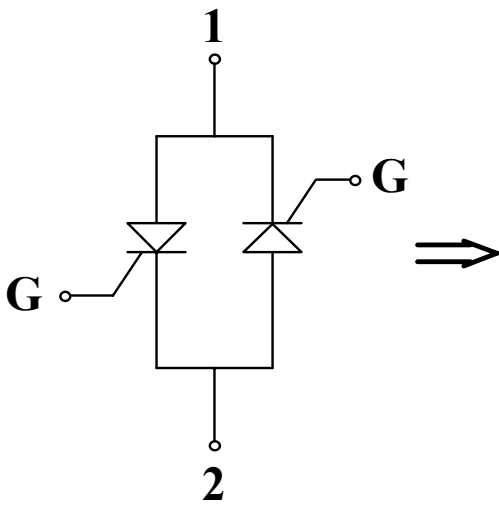

- minore rendimento di pilotaggio rispetto agli scr in antiparallelo
- dispositivi non di elevatissima potenza

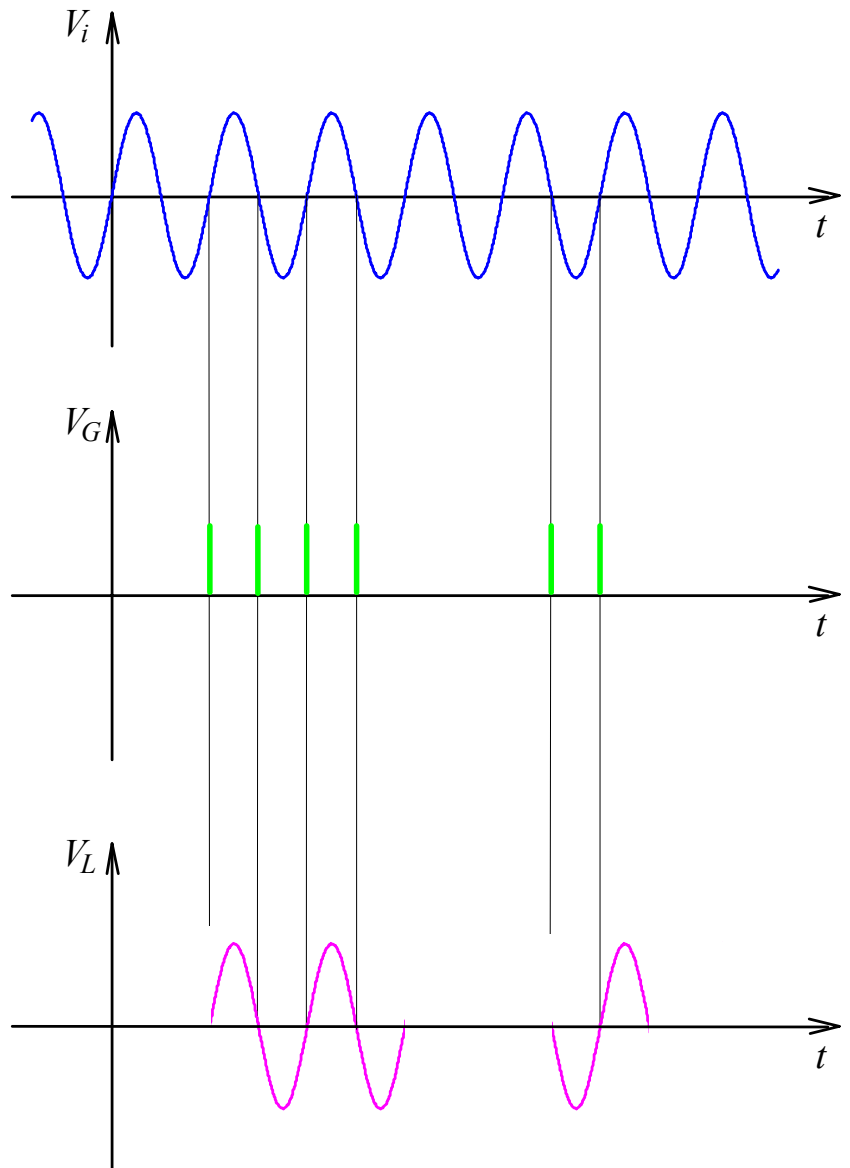

Controllo a "burst"

Modalità di pilotaggio

(a) in continua

(b) in alternata

(c) impulsivo

(a) in continua

▪ basso rendimento

▪ impreciso

▪ sensibile alla temperatura

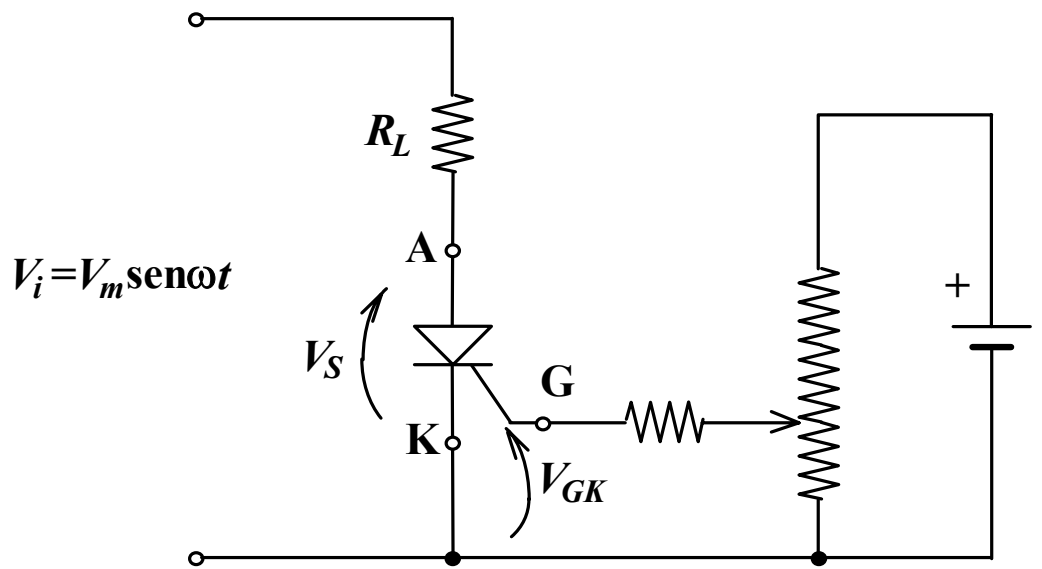

▪ $\varphi_a = 0 \div 90^\circ$

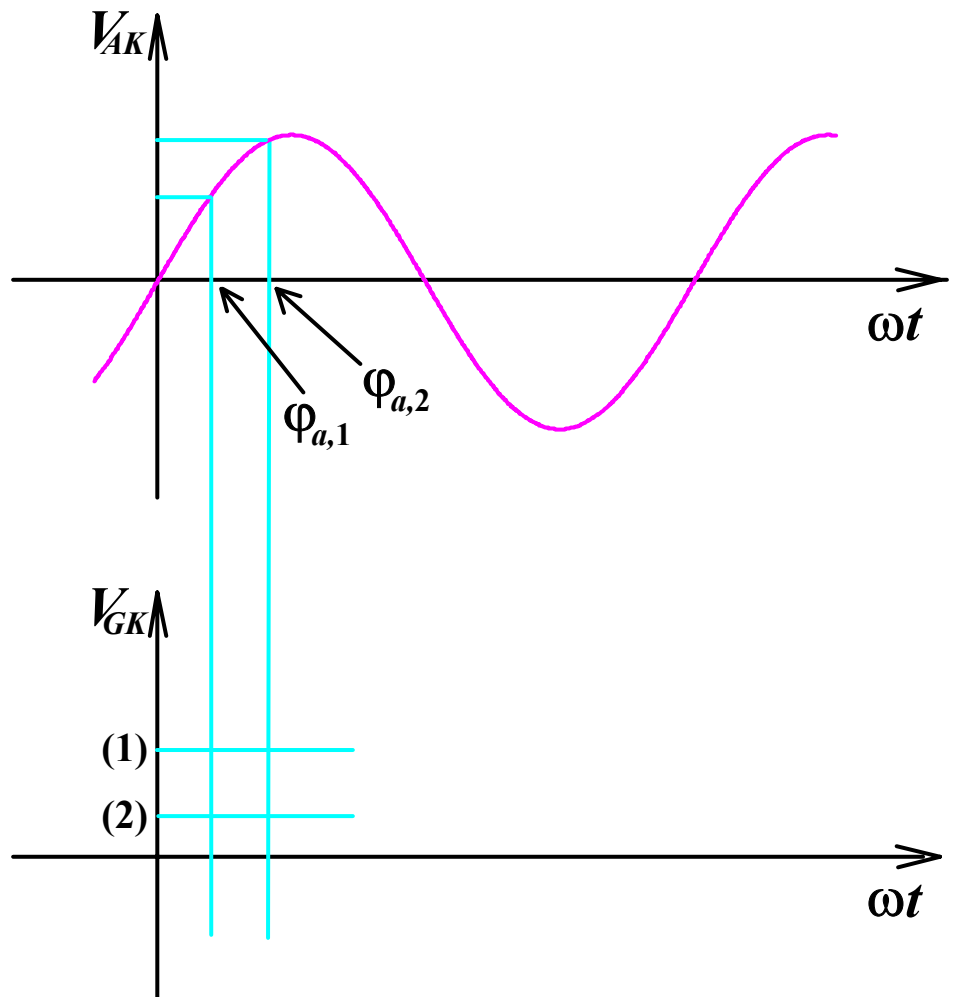

(b) *in alternata*

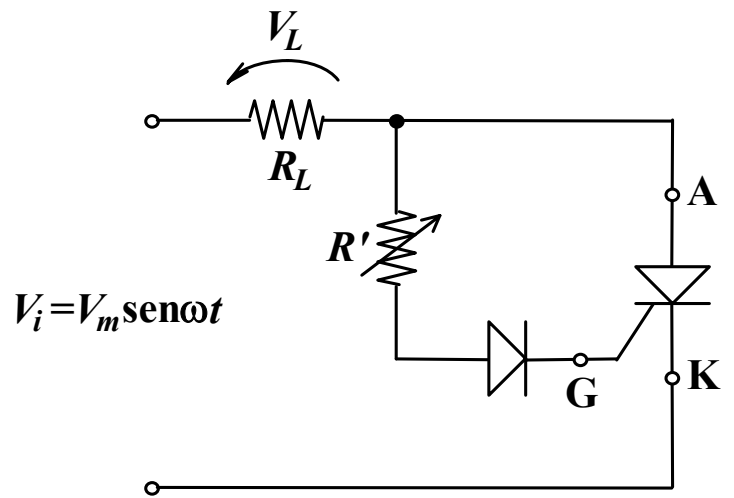
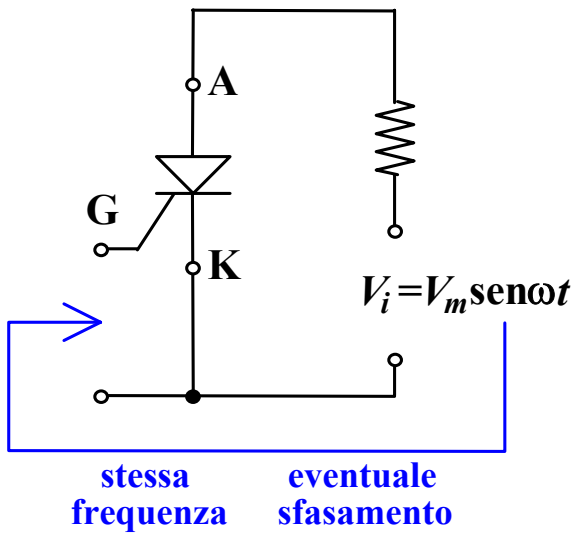

(c) *impulsivo*

- maggiore precisione dell'istante di accensione
- indipendente dalla T

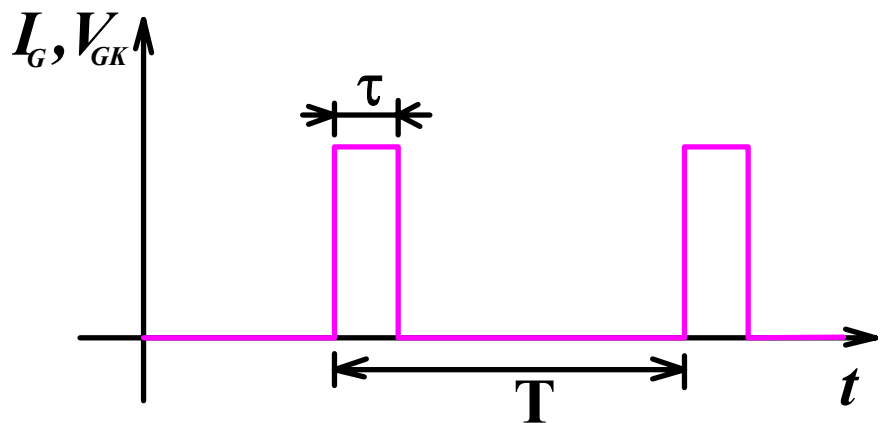

Duty cycle

$$P_D = I_G V_{GK} = \text{potenza di picco}$$

$$P_D \cdot \tau = \text{energia dissipata per impulso}$$

$$\bar{P}_D = P_m = \frac{\tau P_D}{T} \Rightarrow \boxed{\frac{\tau}{T} = \delta} \quad (\text{duty cycle})$$

Problema della dissipazione di potenza

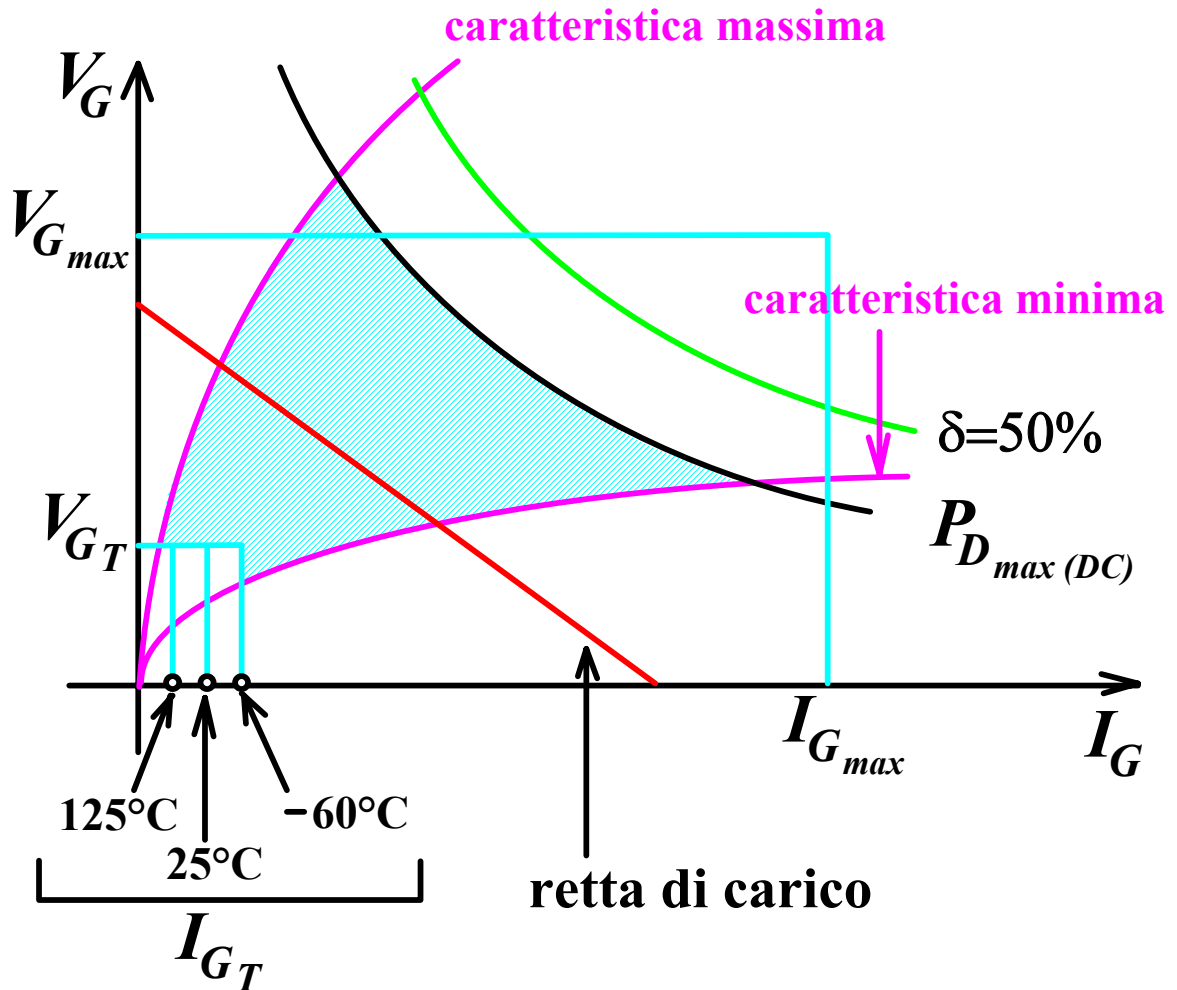

$$\Delta T \Rightarrow \Delta V$$

$$P_D \Rightarrow I$$

$$\theta \Rightarrow R$$

$$\theta = \frac{\Delta T}{P_D} \left[\frac{^\circ\text{C}}{\text{W}} \right]$$

Derating Curve

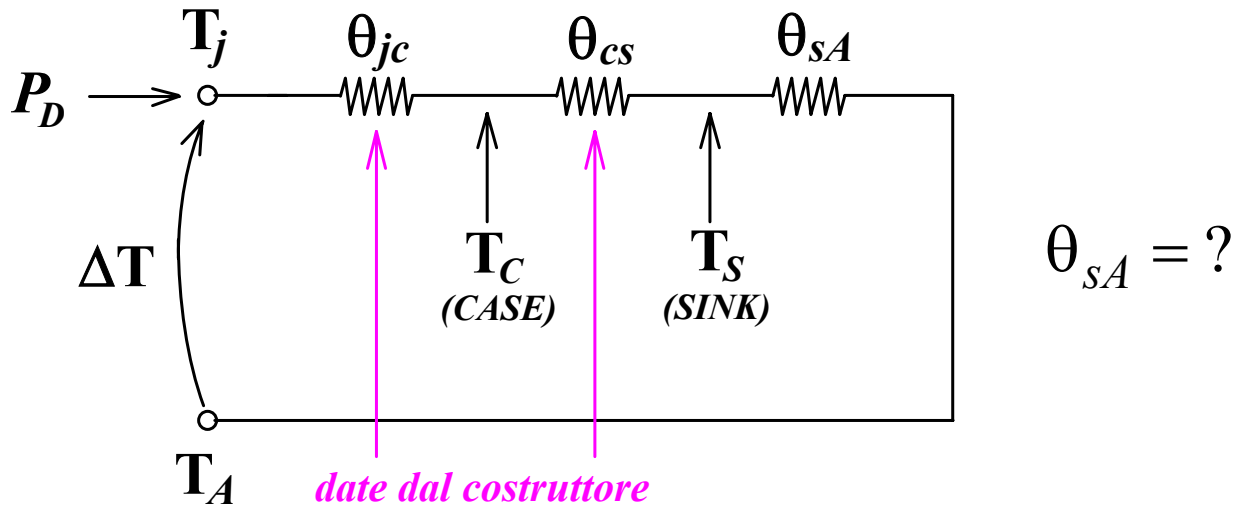

$$\left| \frac{\Delta P_D}{\Delta T} \right| = \frac{1}{\theta_{jc}}$$

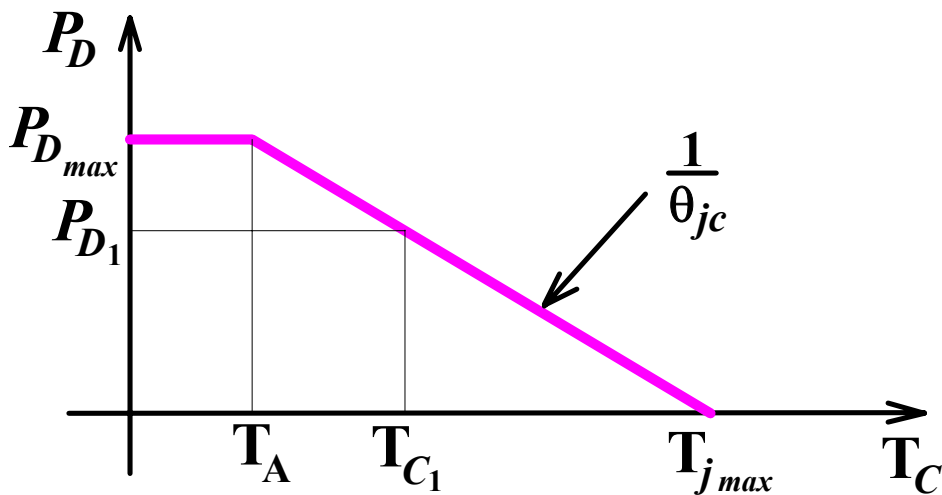

$$P_{D1} = \frac{T_{C1} - T_A}{\theta_{cs} + \theta_{sA}}$$

Le caratteristiche del dissipatore dipendono da:

- **materiale (conducibilità termica)**
- **dimensione (estensione della superficie di scambio)**
- **stato della superficie (liscia, sabbiata, verniciata)**
- **forma (alettata, liscia, ecc.)**
- **tipo di scambio termico utilizzato (conduzione, irradiazione, convezione naturale o forzata)**

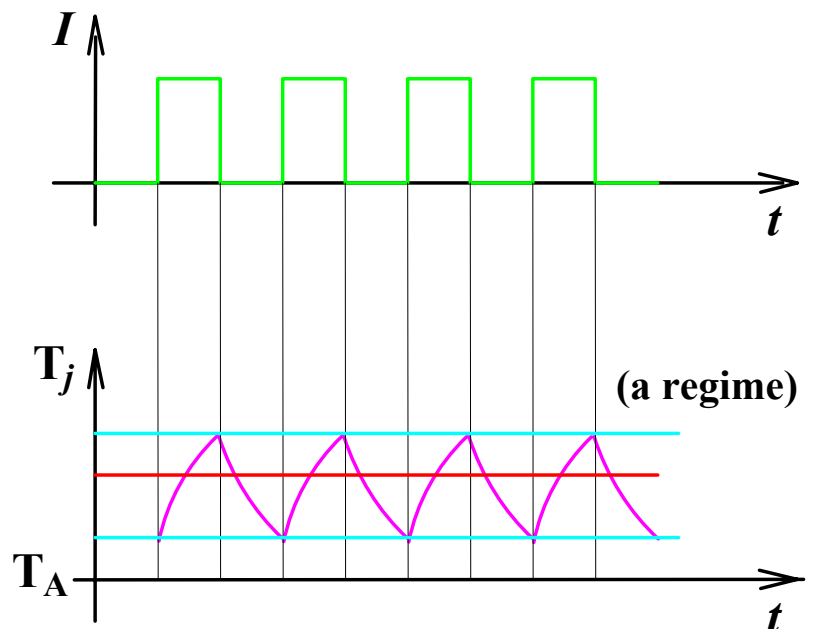
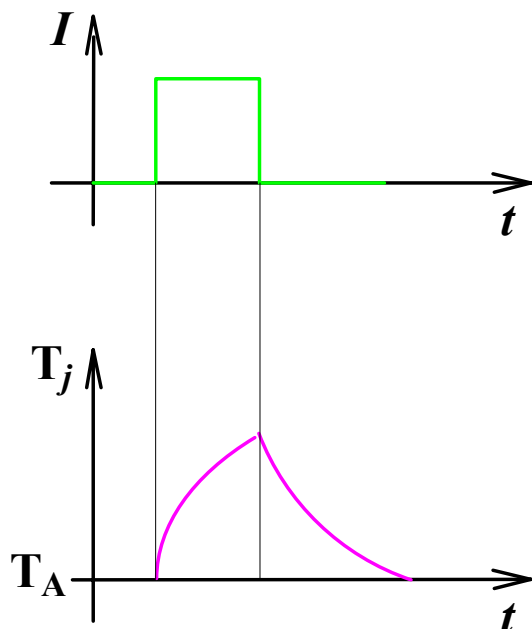
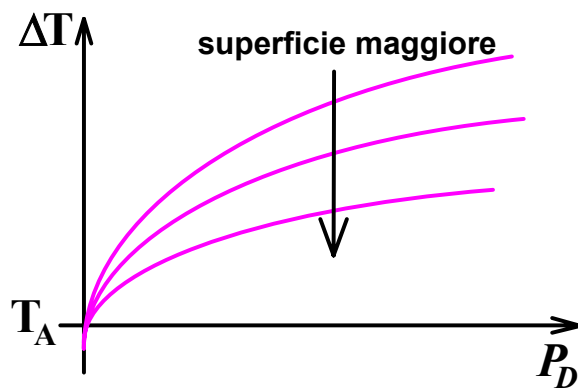

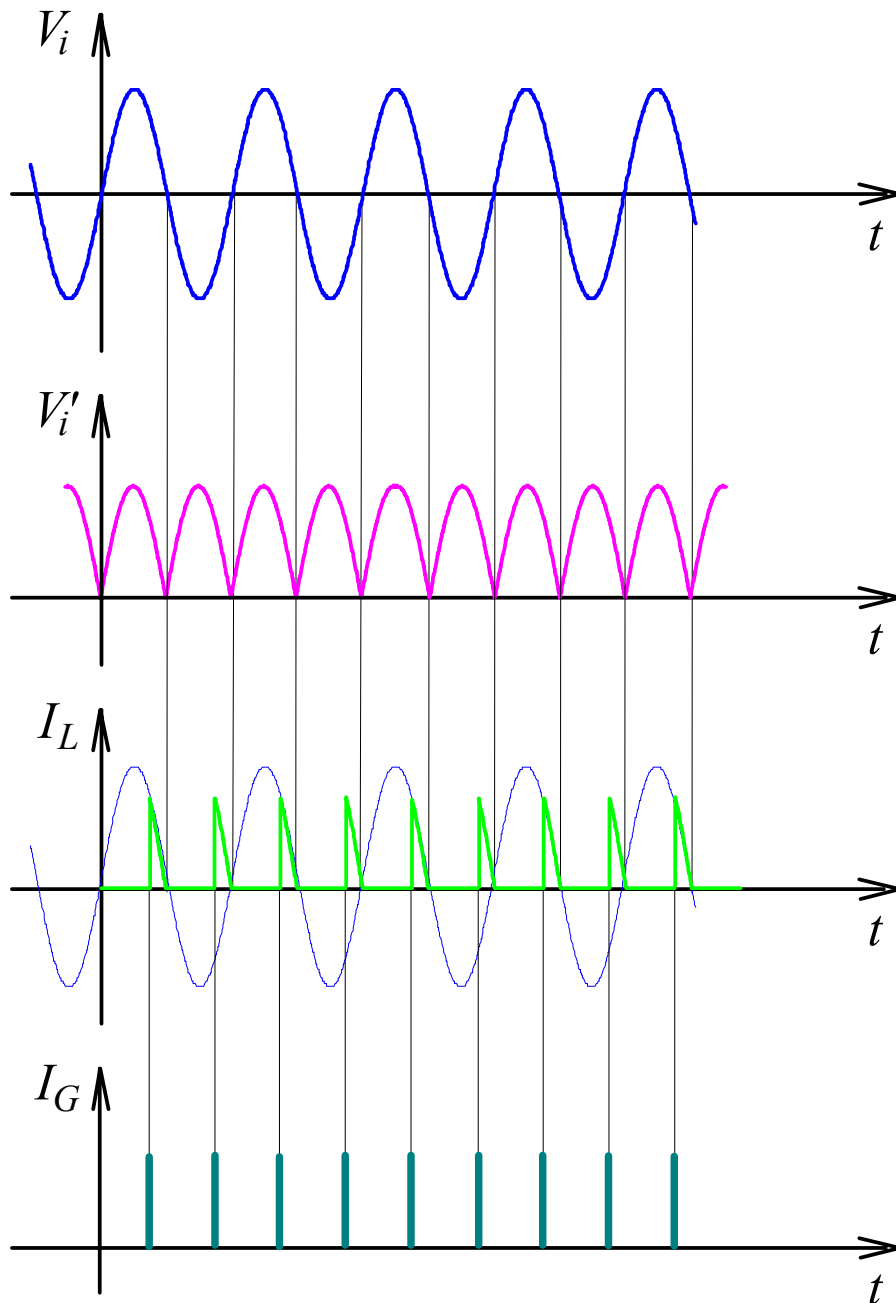
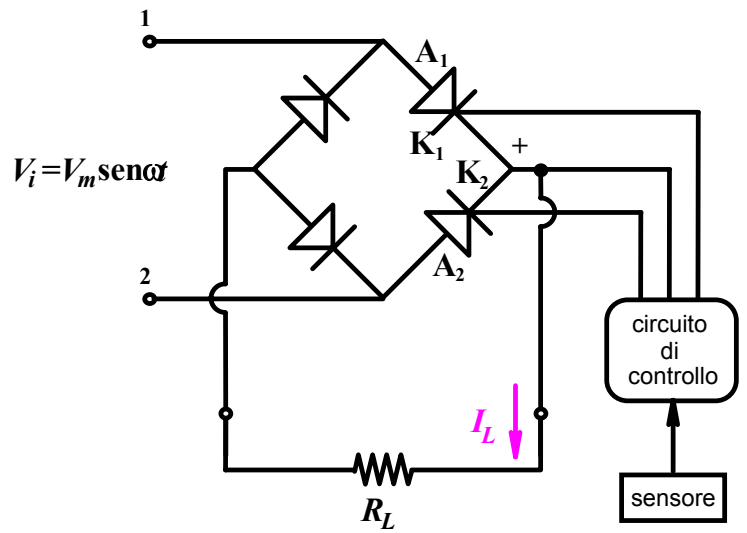
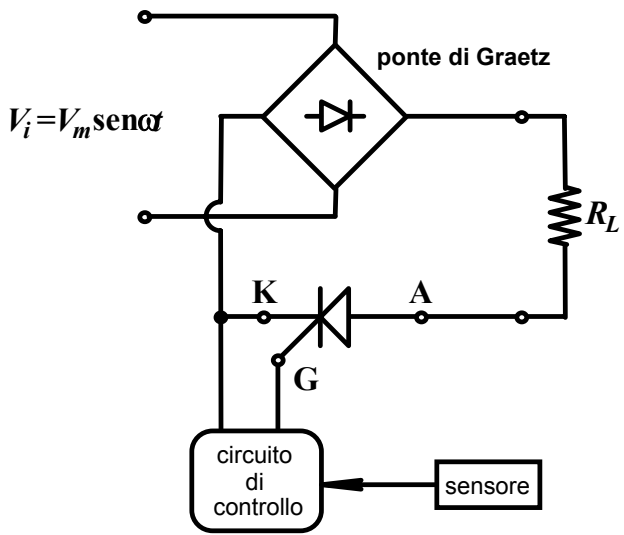

Esempio

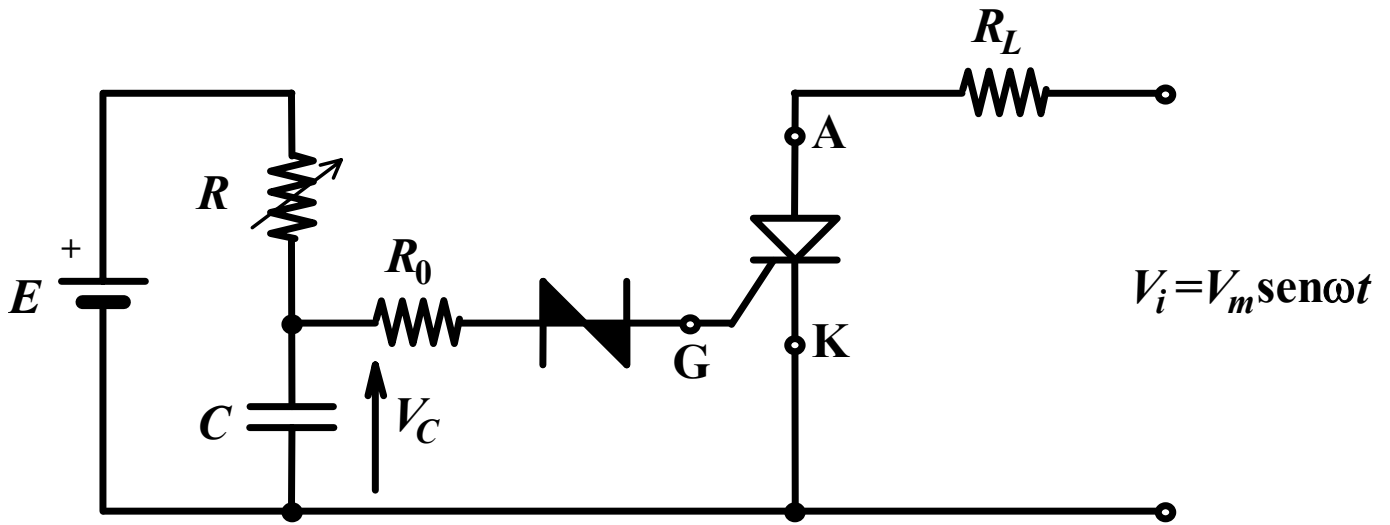

$$V_C - V_{res} = (E - V_{res}) \left(1 - e^{-\frac{t'}{RC}}\right)$$

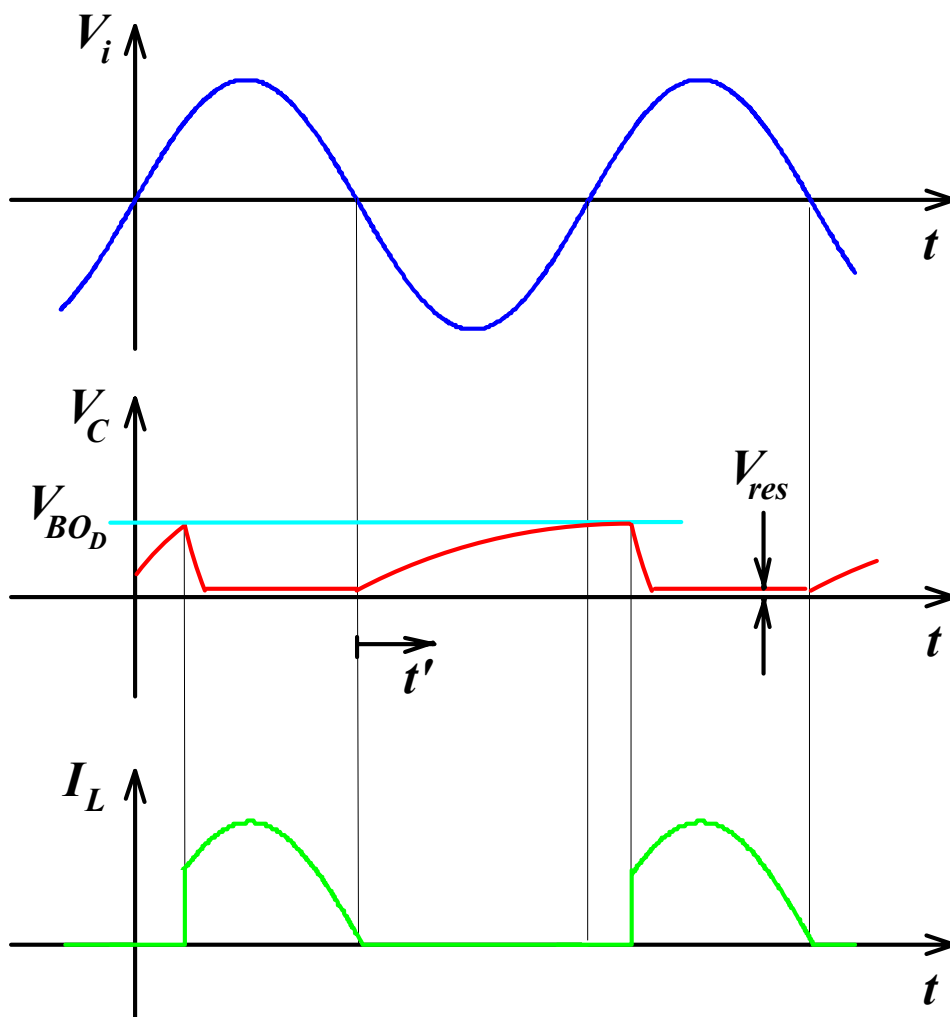

Utilizzo di una rete sfasatrice

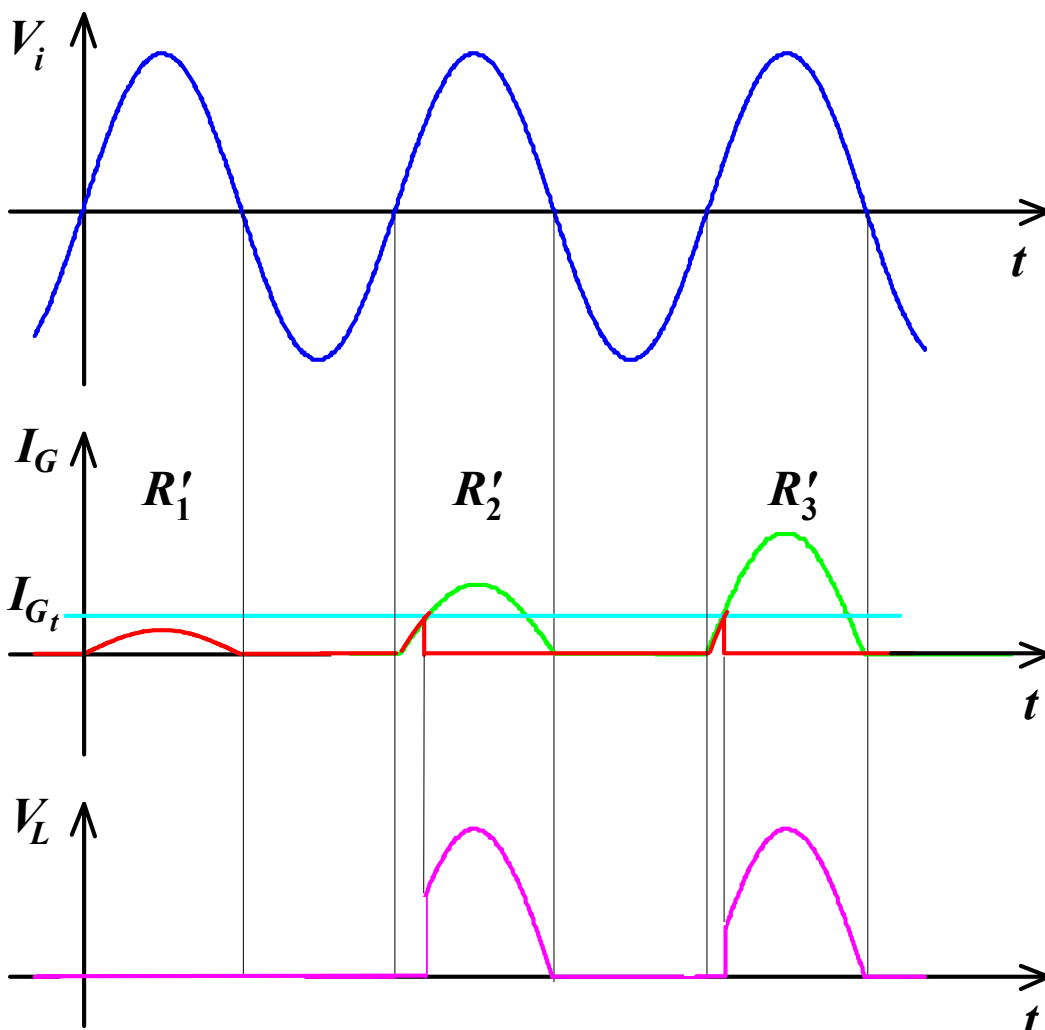
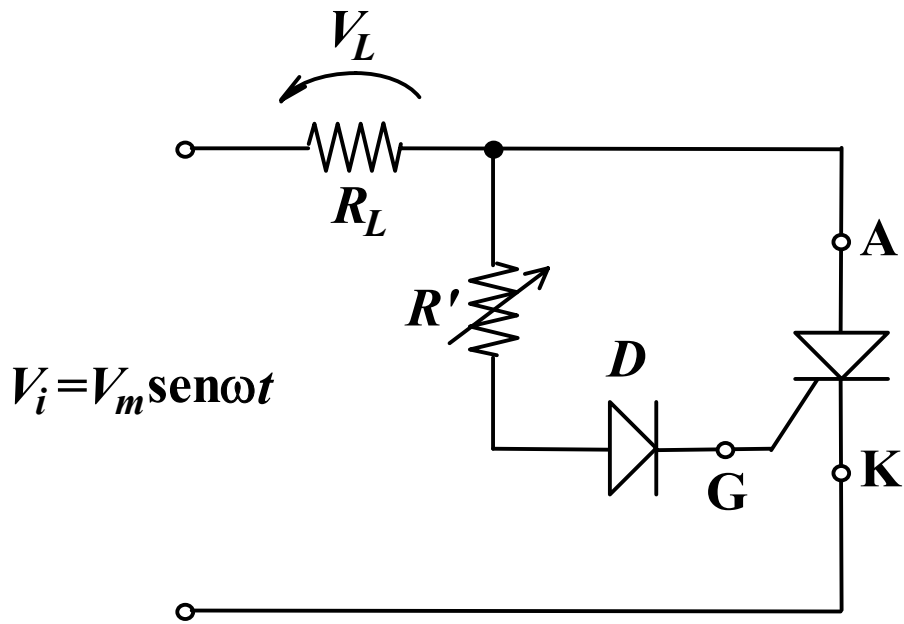

$R'_1 > R'_2 > R'_3$

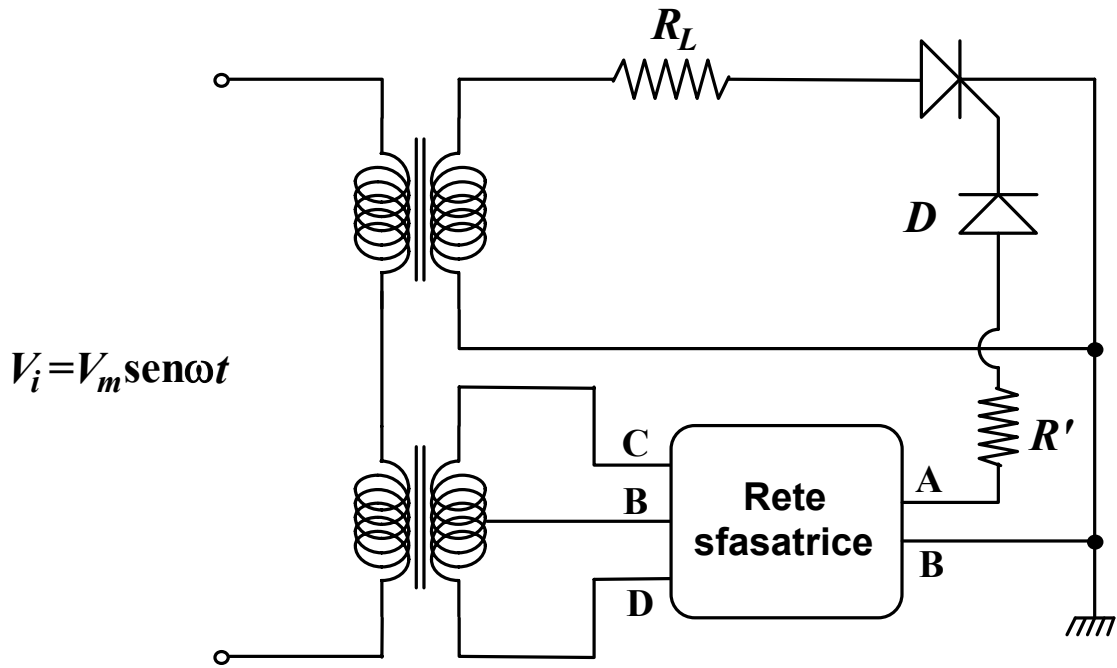

$$V_{CD} = \left(R + \frac{1}{j\omega C} \right) I$$

$$I = \frac{2V_{CB}}{R + \frac{1}{j\omega C}}$$

$$V_{CD} = 2V_{CB}$$

$$V_{AB} = V_{CB} - RI$$

$$V_{AB} = V_{CB} \left(1 - \frac{2R}{R + \frac{1}{j\omega C}} \right) = V_{CB} \left(\frac{1 - j\omega RC}{1 + j\omega RC} \right) \Rightarrow |V_{AB}| = |V_{CB}|$$

$$V_{AB} = |V_{CB}| e^{j\varphi}$$

$$\text{con } \varphi = -2 \arctg \omega RC$$

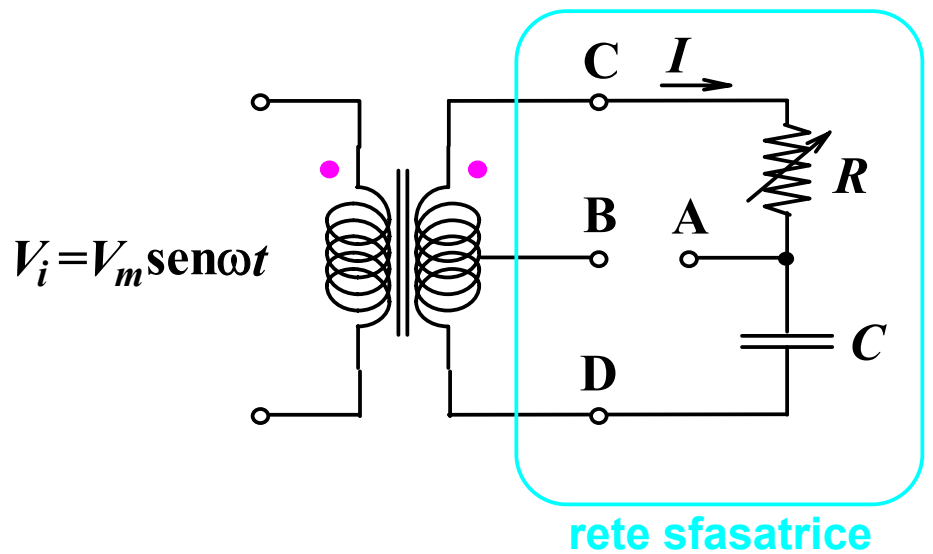

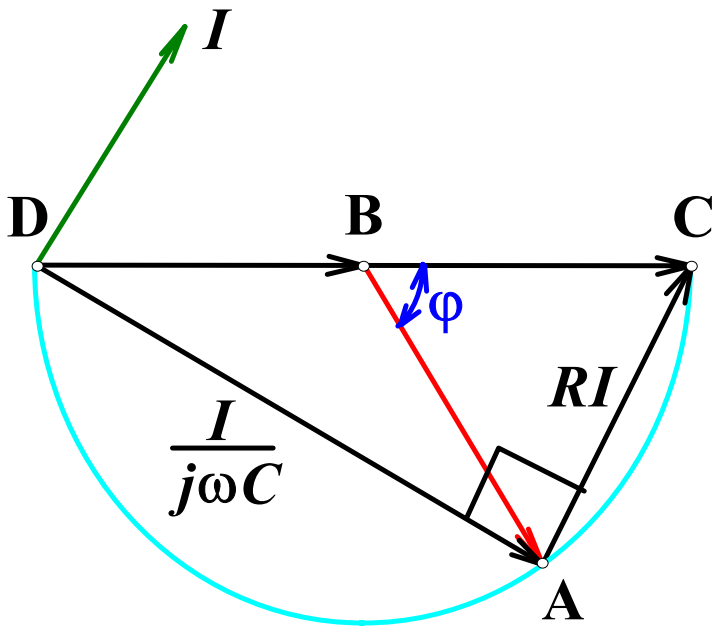

$V_i = 0^\circ$

$R \rightarrow 0 \Rightarrow \varphi \rightarrow 0^\circ$
 $R \rightarrow \infty \Rightarrow \varphi \rightarrow 180^\circ$

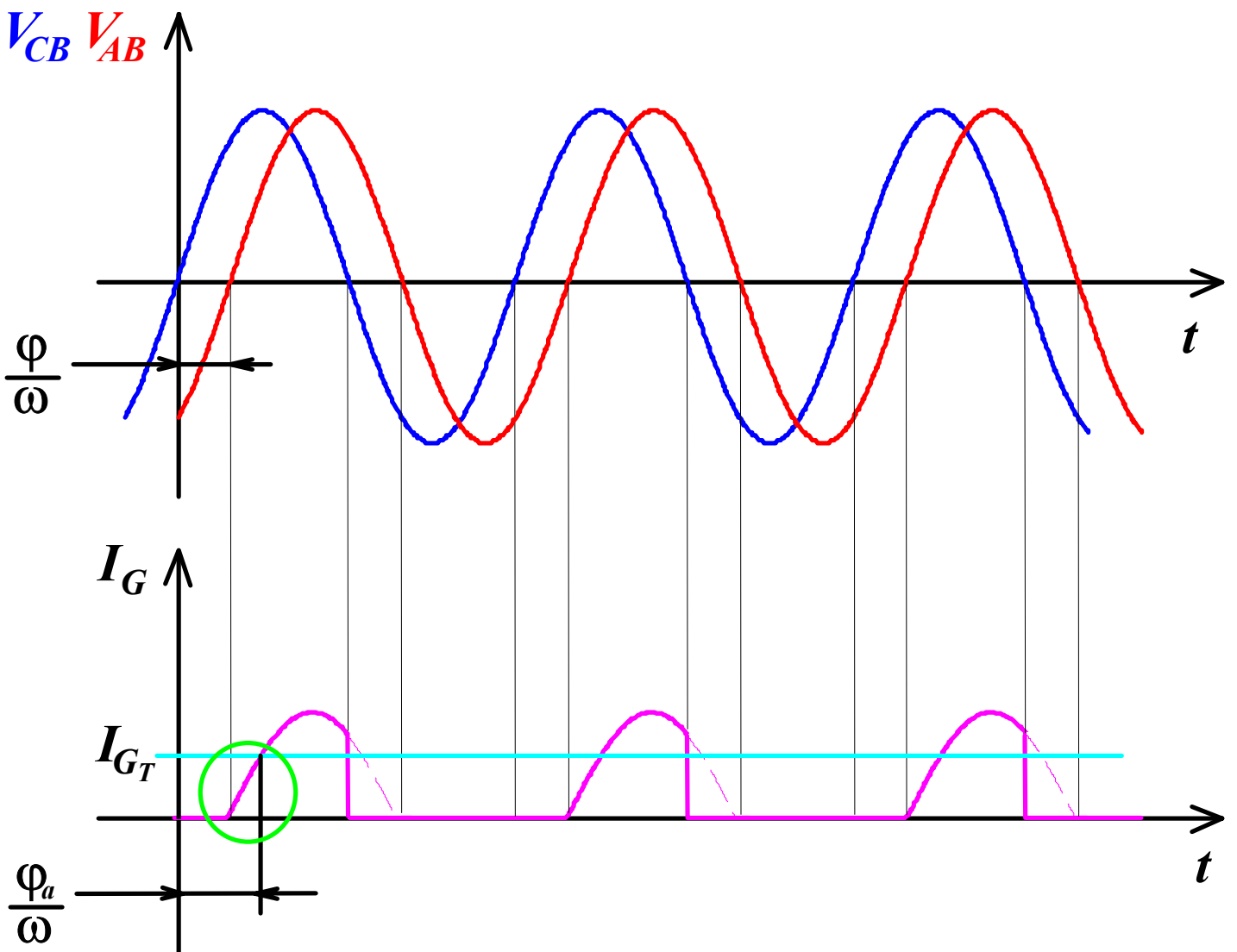

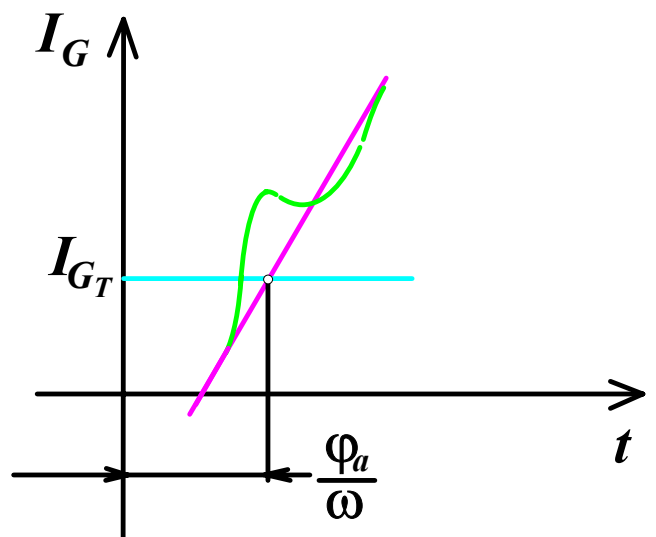
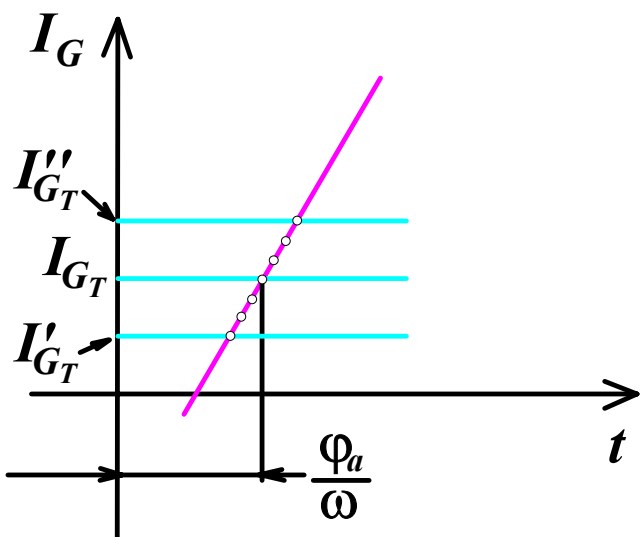
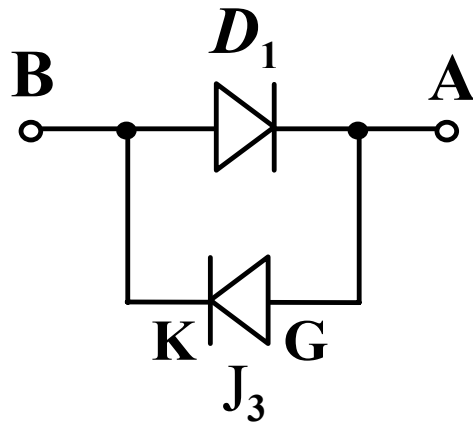
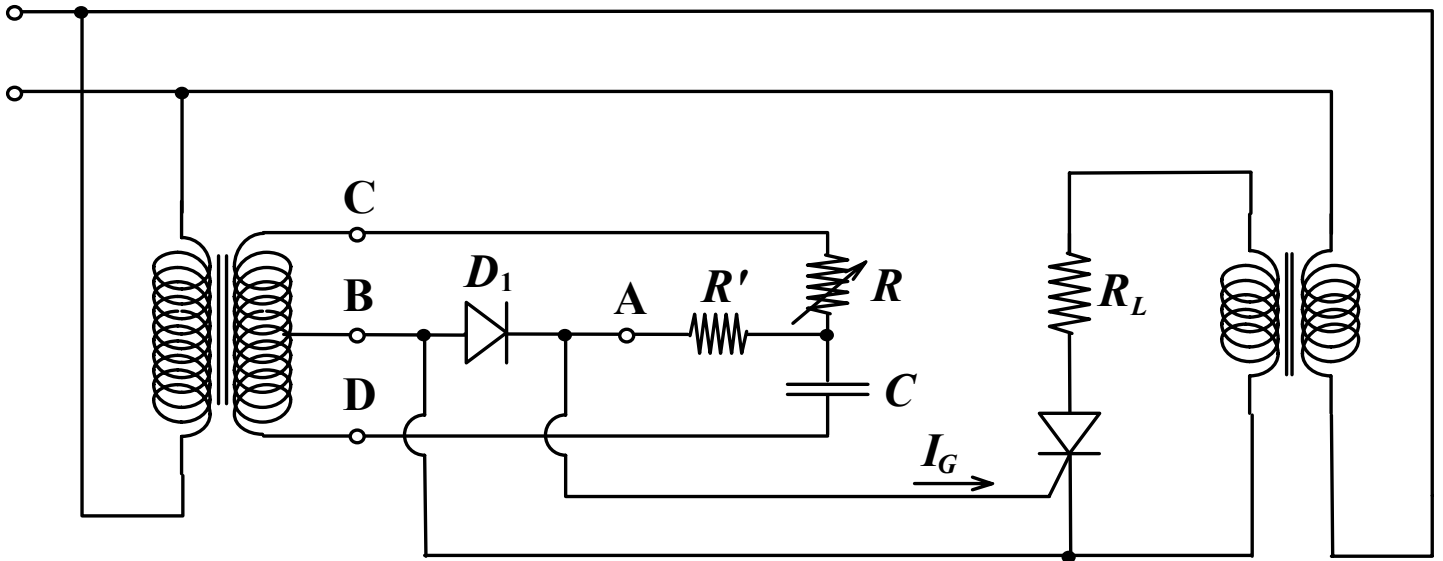

Utilizzo di una rete smorzatrice (snubber)

Problema: $\frac{di}{dt}$ $\frac{dv_{AK}}{dt}$

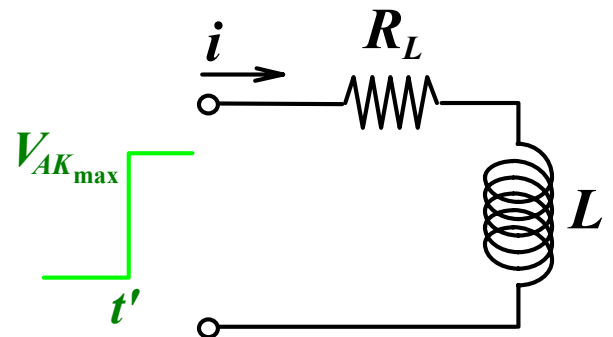
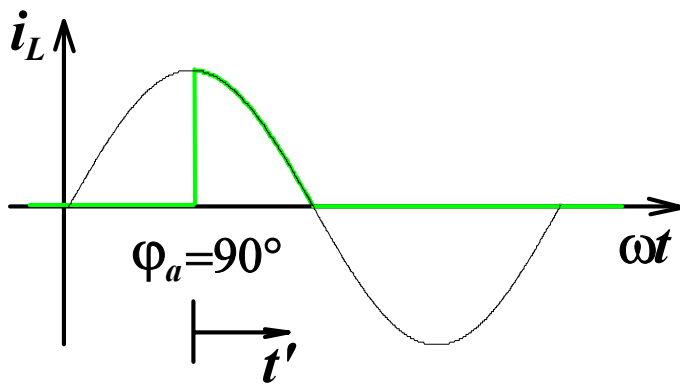
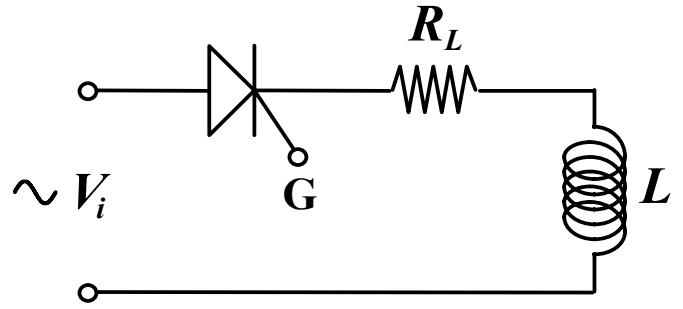

$$i(t') = A + B e^{-\frac{t'}{\tau}} \quad \text{con } \tau = \frac{L}{R_L}$$

$$i(0) = 0 \Rightarrow A = -B$$

$$i_{t \rightarrow \infty} = \frac{V_{AK_{max}}}{R_L} = A \Rightarrow i(t') = \frac{V_{AK_{max}}}{R_L} (1 - e^{-\frac{t'}{\tau}})$$

$$\frac{di}{dt'} = \frac{V_{AK_{max}}}{R_L \cdot \frac{L}{R_L}} e^{-\frac{t'}{\tau}} \Rightarrow$$

$$\left. \frac{di}{dt'} \right|_{\max} = \frac{V_{AK_{max}}}{L}$$

$$\text{Hp: } \left. \frac{di}{dt'} \right|_{\max} = \frac{100 \text{ A}}{\mu\text{s}} \Rightarrow L = \frac{V_{AK\max}}{\left. \frac{di}{dt'} \right|_{\max}} = \frac{300 \text{ V}}{\frac{100 \text{ A}}{\mu\text{s}}} \approx 3 \cdot 10^{-6} \text{ H}$$

$$\left. \frac{dv_{AK}}{dt} \right|_{\max} = ?$$

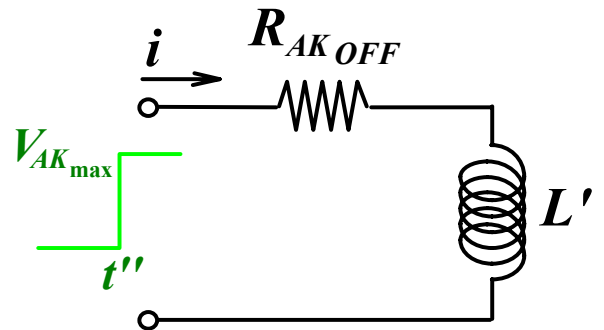
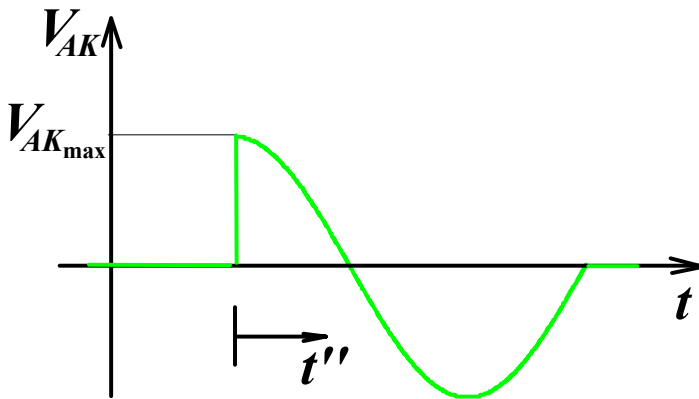
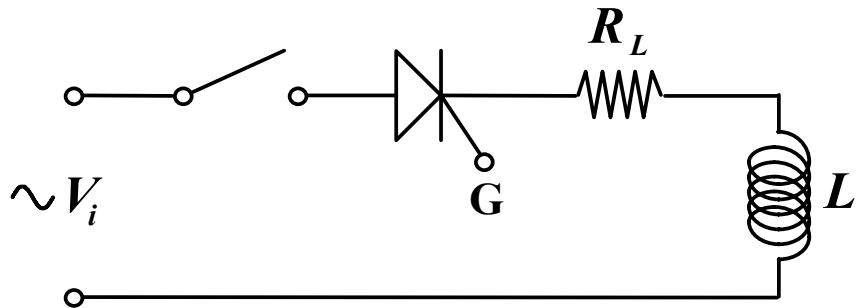

$$\text{Hp: } I_{\text{OFF}} = 10\text{mA} \Rightarrow R_{AK\text{OFF}} = \frac{300}{10^{-2} \text{ A}} = 30\text{k}\Omega \gg R_L$$

$$i(t'') = \frac{V_{AK\max}}{R_{AK\text{OFF}}} (1 - e^{-\frac{t''}{\tau'}}) \quad \text{con } \tau' = \frac{L}{R_{AK\text{OFF}}}$$

$$v_{AK}(t) = R_{AK\text{OFF}} \cdot i = V_{AK\max} (1 - e^{-\frac{t''}{\tau'}})$$

$$\frac{dv_{AK}}{dt''} = \frac{V_{AK\max}}{\tau'} e^{-\frac{t''}{\tau'}} \Rightarrow \left. \frac{dv_{AK}}{dt''} \right|_{\max} = \frac{R_{AK\text{OFF}} V_{AK\max}}{L}$$

$$\text{Hp: } \frac{dv_{AK}}{dt''} = \frac{300\text{V}}{\mu\text{s}} \Rightarrow L' = \frac{R_{AKOFF} V_{AK\max}}{\left. \frac{dv_{AK}}{dt} \right|_{\max}} = \frac{30 \cdot 10^3 \Omega \cdot 300 \text{ V}}{300 \cdot 10^6 \frac{\text{V}}{\text{s}}} = \mathbf{30 \text{ mH} \text{ (!)}}$$

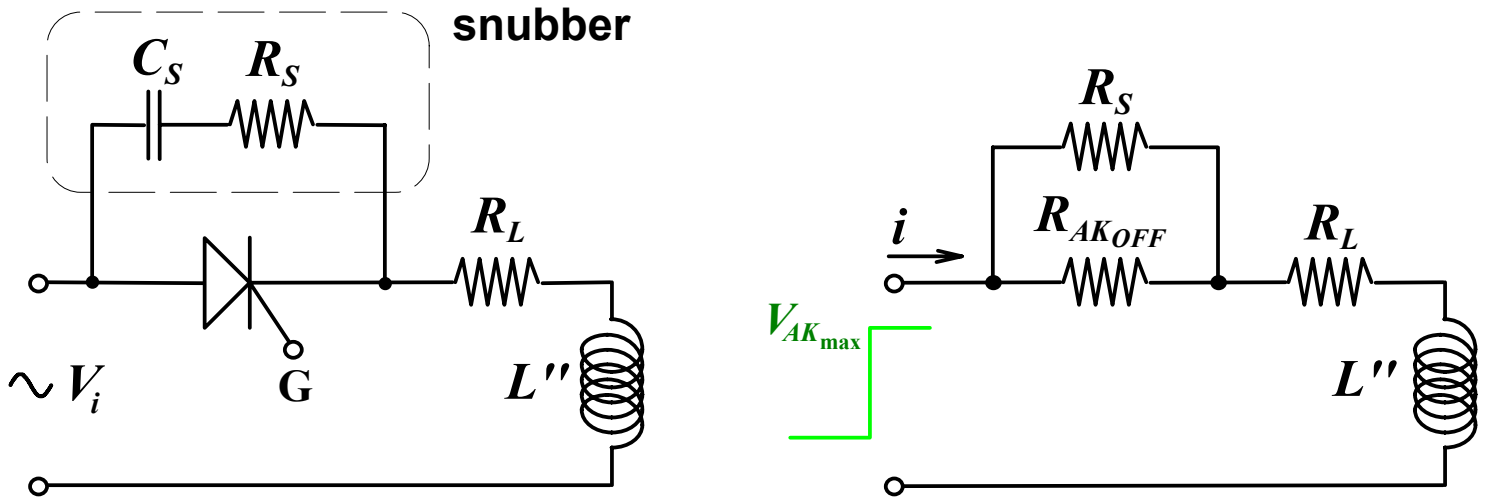

$$\left. \frac{dv_{AK}}{dt''} \right|_{\max} = \frac{V_{AK\max}}{L''} R_S$$

⇓

$$\text{Hp: } R_S = \frac{1}{1000} R_{AKOFF}$$

⇓

$$L'' = \frac{L'}{1000} = 30 \mu\text{H}$$

Tipicamente $R_S = 10 \div 15 \Omega (\gg R_L)$ $C_S = 100 \text{ nF}$

~~$C_S \uparrow$~~ ~~$R_S \downarrow$~~

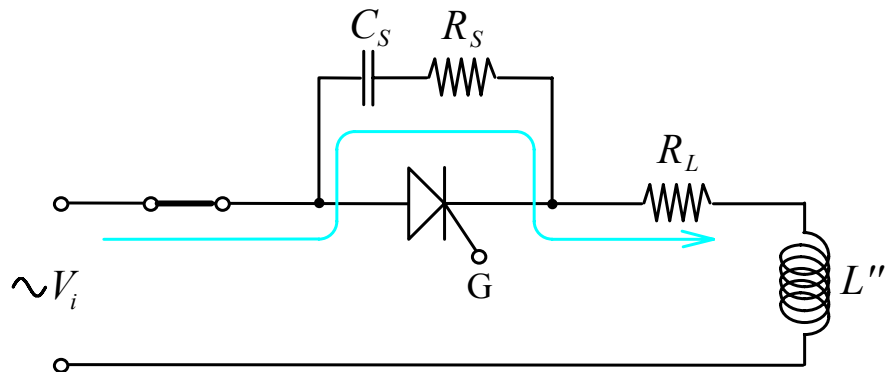

Alimentatori

a dissipazione
(*< 50W*)

a commutazione
(*fino a 2kW*)

Rendimento di un alimentatore

$$\eta = \frac{P_{CARICO}}{P_{RETE}} = \frac{\text{Potenza ceduta al carico}}{\text{Potenza assorbita dalla sorgente primaria}}$$

Problemi connessi: consumo, riscaldamento ⇒ smaltimento calore

Raffronto tra le caratteristiche degli alimentatori

	<i>Alimentatori a dissipazione</i>	<i>Alimentatori a commutazione</i>	SVANTAGGI VANTAGGI
<i>Rendimento (η)</i>	25÷50%	75÷90%	
<i>Peso</i>	5kg/100W	2kg/100W	
<i>Ingombro</i>	10dm ³ /100W	2dm ³ /100W	
<i>Generazione di disturbi</i>	NO	SI	
<i>Sensibilità ai disturbi</i>	NULLA	SI	

Alimentatori a dissipazione

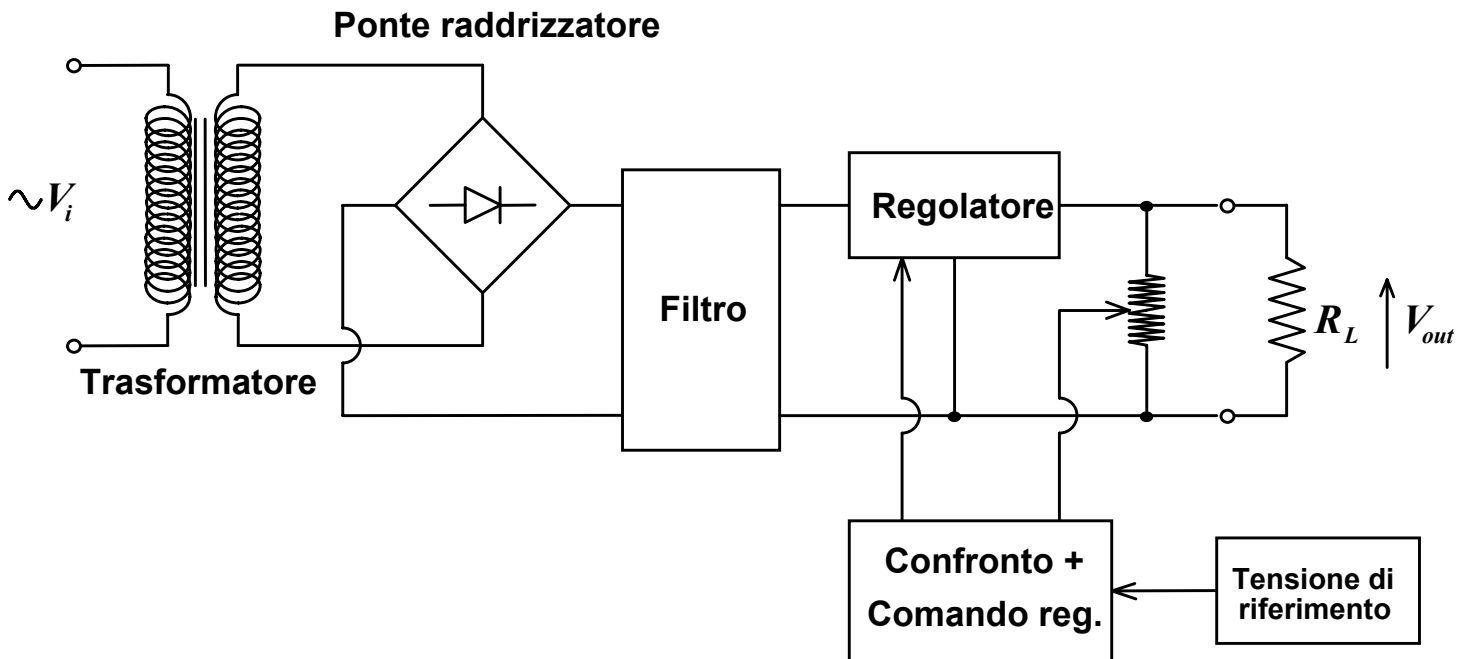

Esempio: alimentatore stabilizzato a diodo Zener

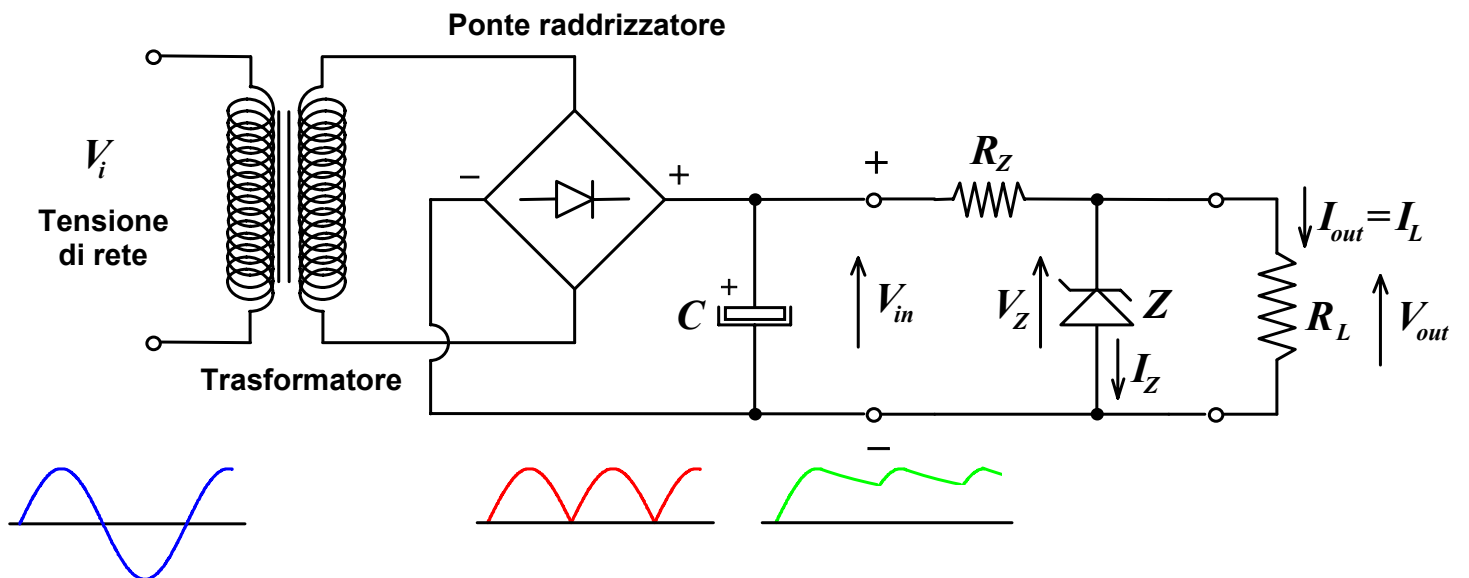

Alimentatori a commutazione
(SMPS=Switched Mode Power Supply)

Schema a secondario

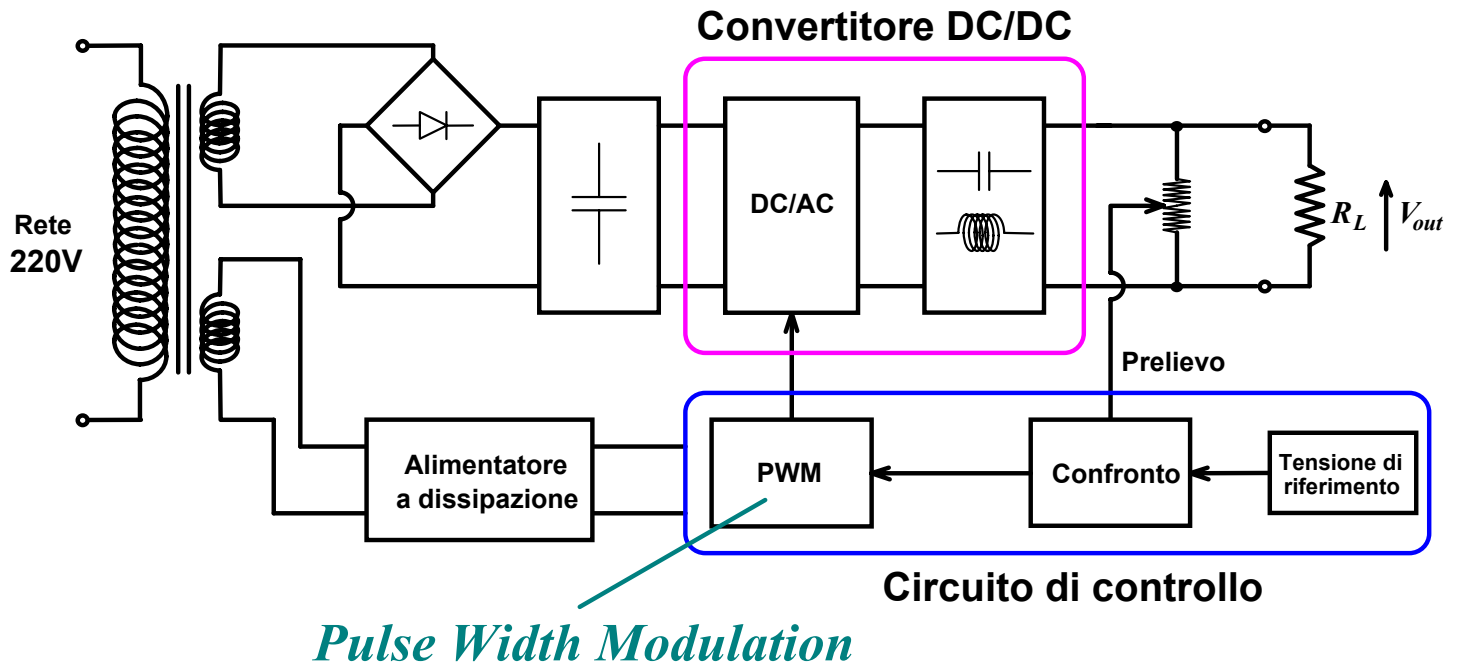

Schema a primario

(Vantaggi: ridotte dimensioni del trasformatore e degli elementi reattivi dei filtri)

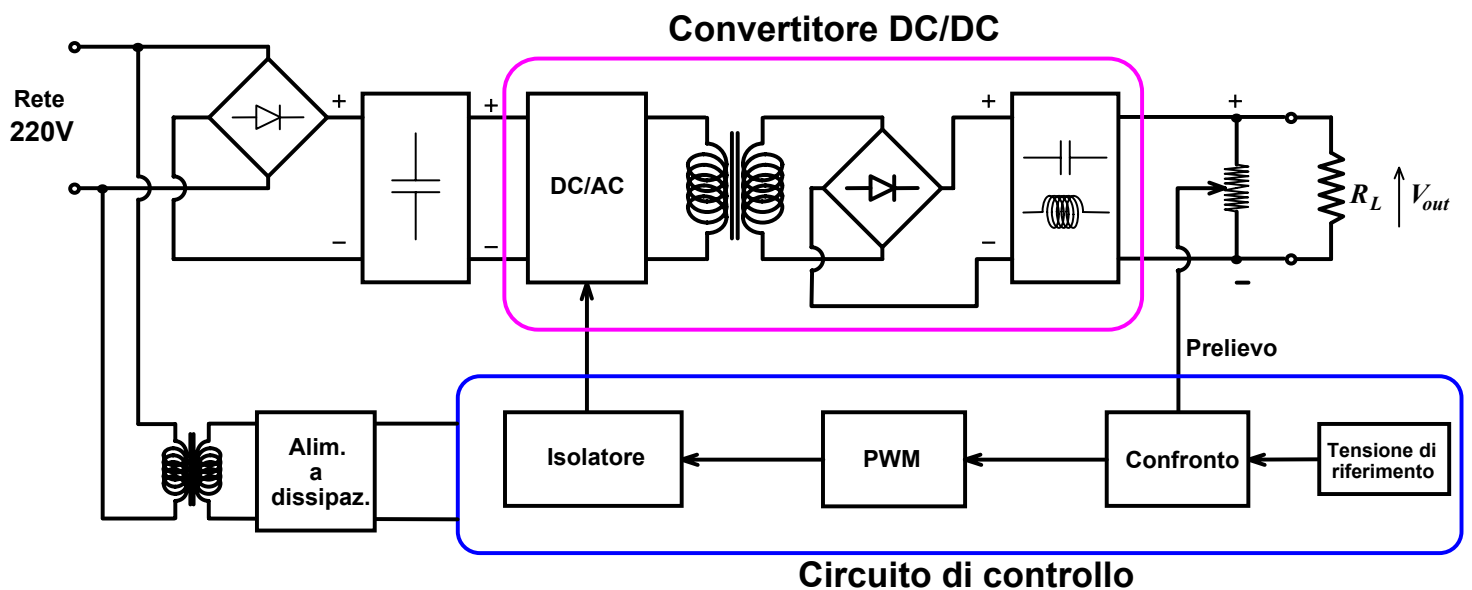

Convertitore DC/DC buck (step-down)

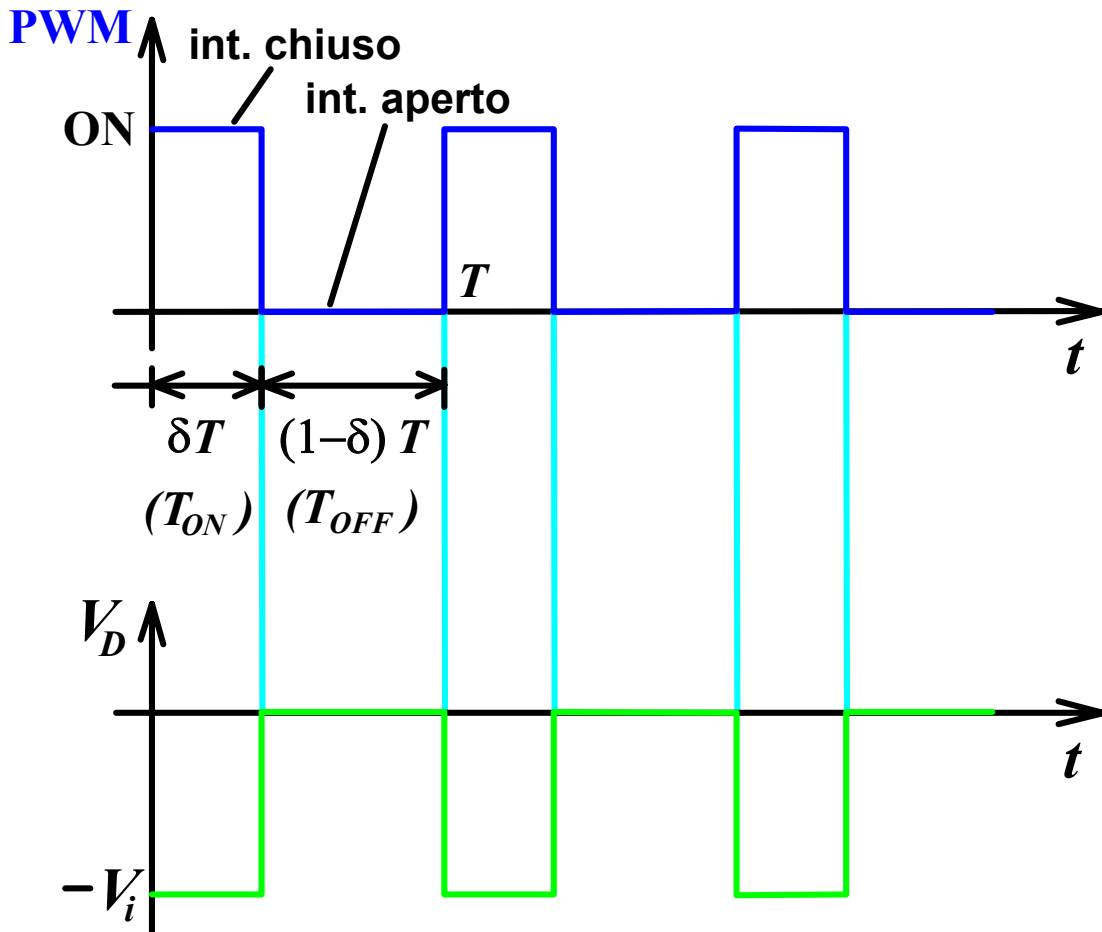
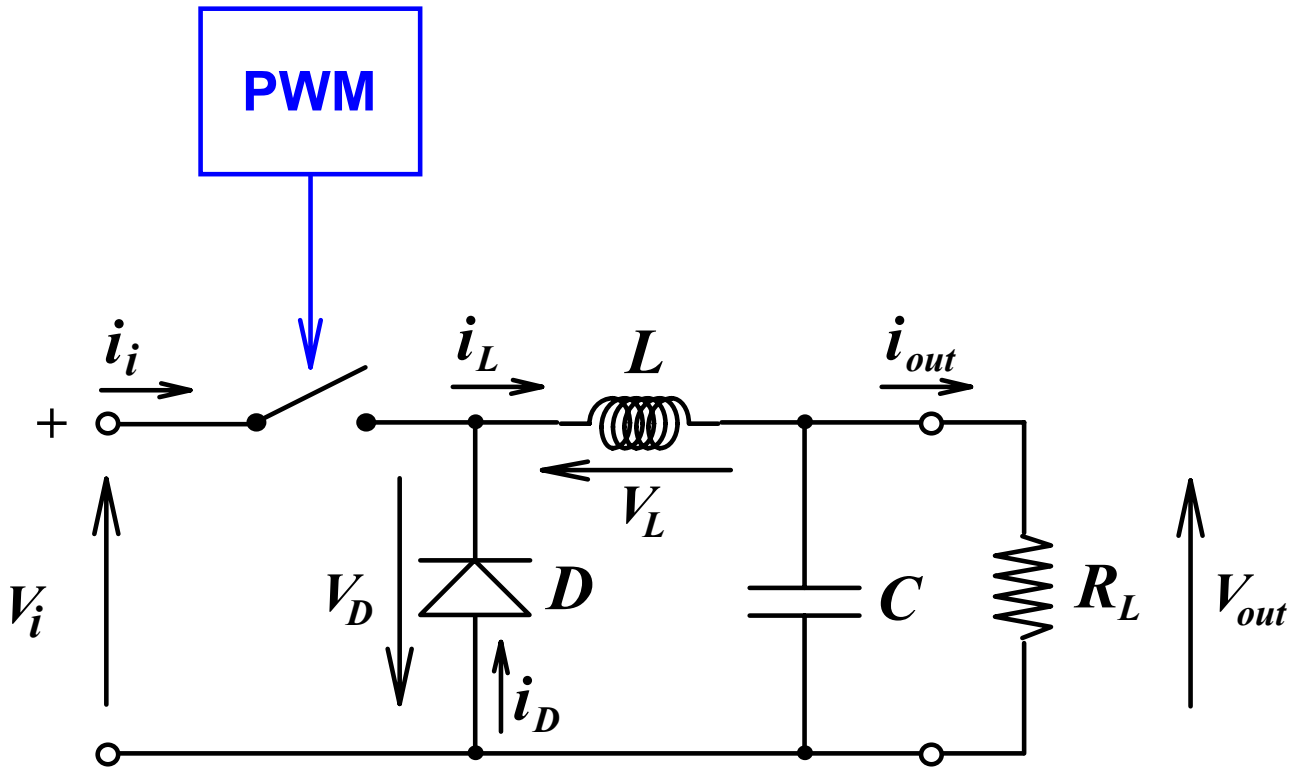

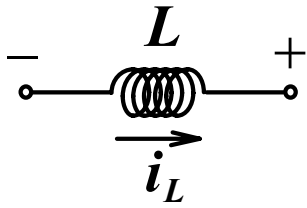

$$v_L = L \frac{di_L}{dt}$$

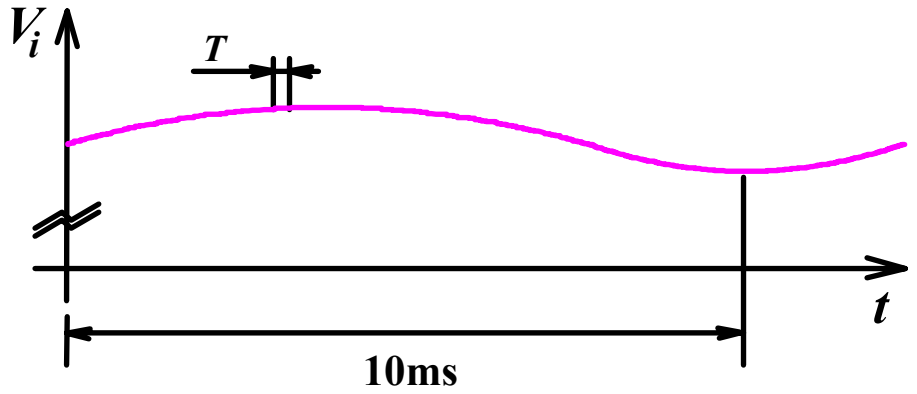

frequenza di commutazione: **20÷200 kHz**

<i>Intervallo</i> $T_{ON} = \delta T$	<i>Intervallo</i> $T_{OFF} = (1 - \delta) T$
$i_L = \frac{1}{L} \int_0^t (V_i - V_{out}) dt + I(0)$ <p><i>(I(0) = valore di i_L per $t=0$)</i></p> <p style="text-align: center;">⇓</p> $i_L = \frac{V_i - V_{out}}{L} t + I(0)$	$V_L = -V_\gamma - V_{out} \cong -V_{out}$ $t' = t - \delta T$ <p><i>(I'(0) = valore di i_L per $t'=0$)</i></p> <p style="text-align: center;">⇓</p> $i_L = \frac{1}{L} (-V_{out}) t' + I'(0)$

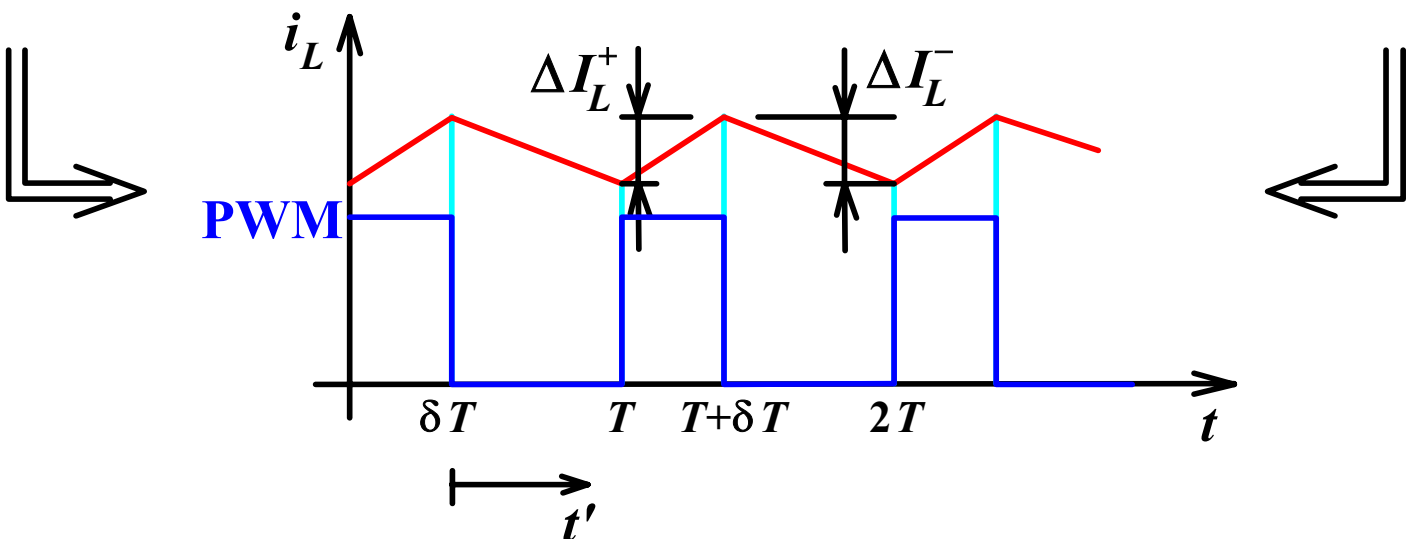

$$\Delta I_L^+ = \frac{V_i - V_{out}}{L} \delta T \quad \Delta I_L^- = \frac{V_{out}}{L} (1 - \delta) T$$

⇓

$$\Delta I_L^+ = \Delta I_L^-$$

⇓

$$\frac{V_i - V_{out}}{L} \delta T = \frac{V_{out}}{L} (1 - \delta) T \Rightarrow V_i \delta T - V_{out} \delta T = V_{out} - V_{out} \delta T$$

⇓

$$V_{out} = \delta V_i$$

Buck, Step-down, Forward

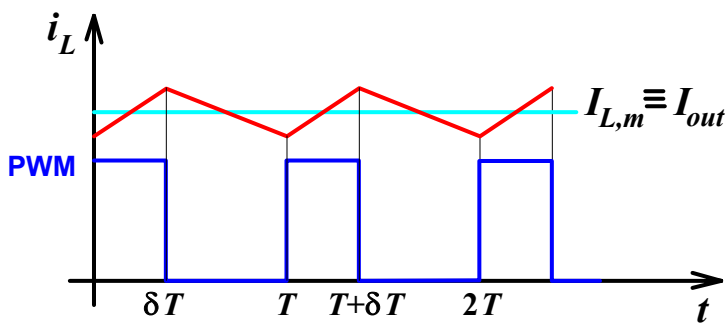

$$I_{i,m} \cdot T = I_{L,m} \cdot \delta T = I_{out} \cdot \delta T$$

⇓

$$I_{out} = \frac{I_{i,m}}{\delta}$$

⇓

$$V_{out} I_{out} = I_{i,m} V_i$$

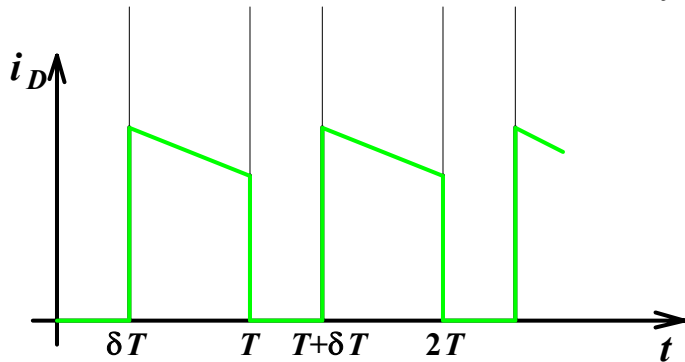
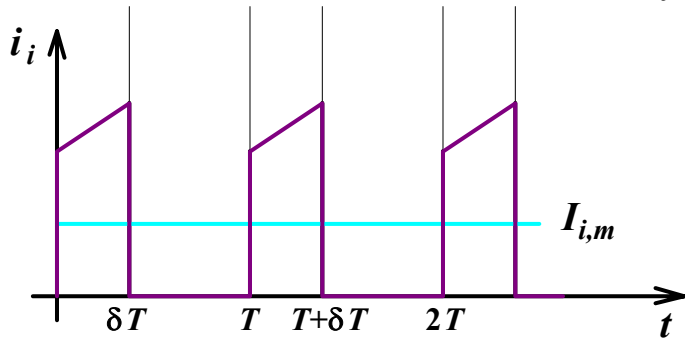

«TRASFORMATORE IN CONTINUA»

CONVERTITORE DC/DC

Perdite di potenza dovute al commutatore

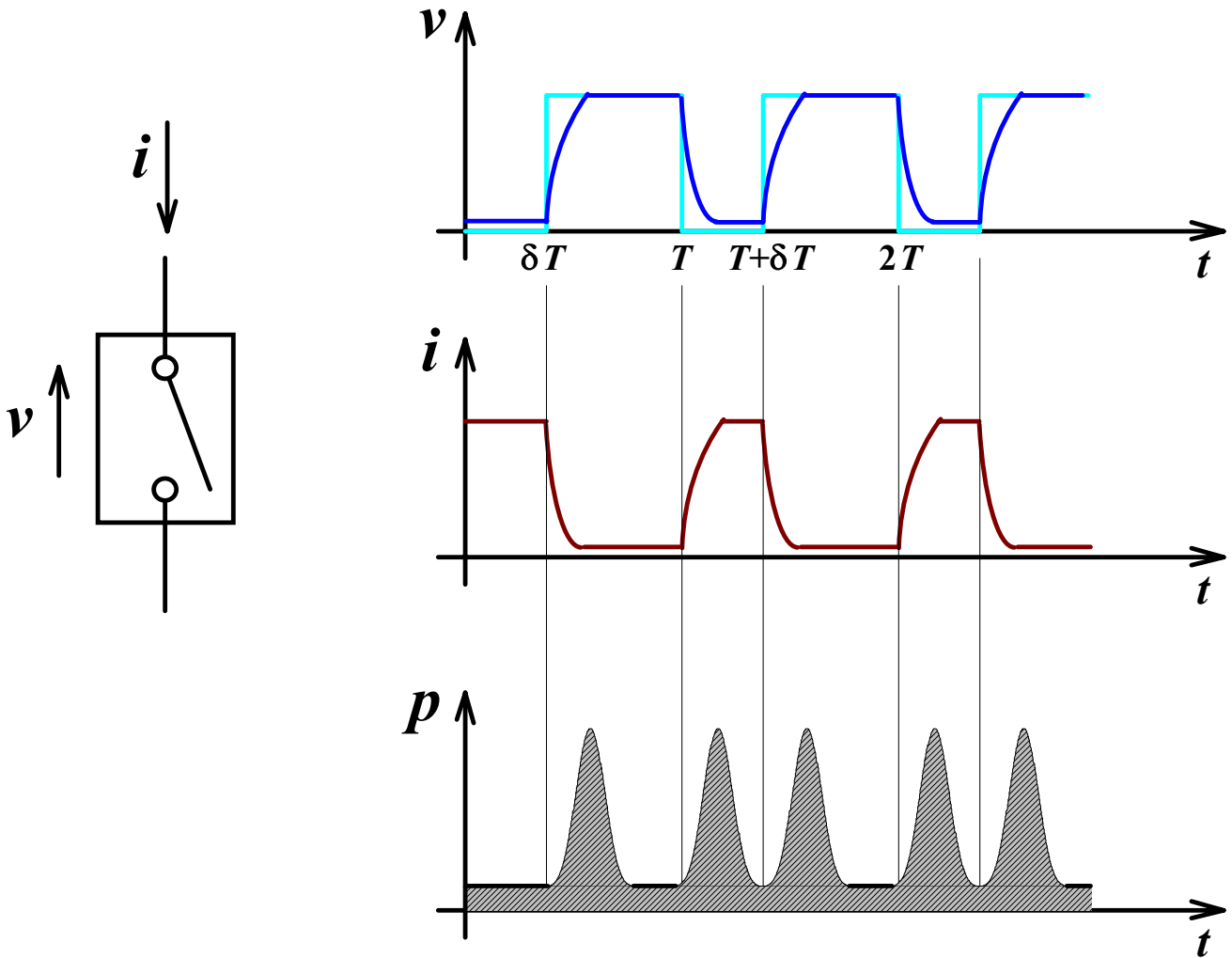

Funzionamento discontinuo \Rightarrow generazione di disturbi

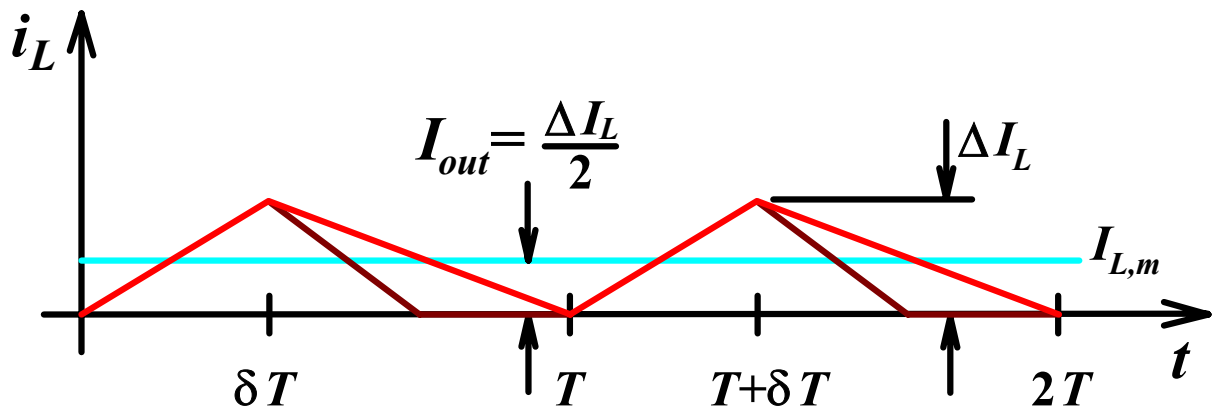

$$L = L_{\min} = \frac{(V_i - V_{out}) \delta T}{2 I_{out, \min}} \Rightarrow \Delta I_L$$

Filtro di rete

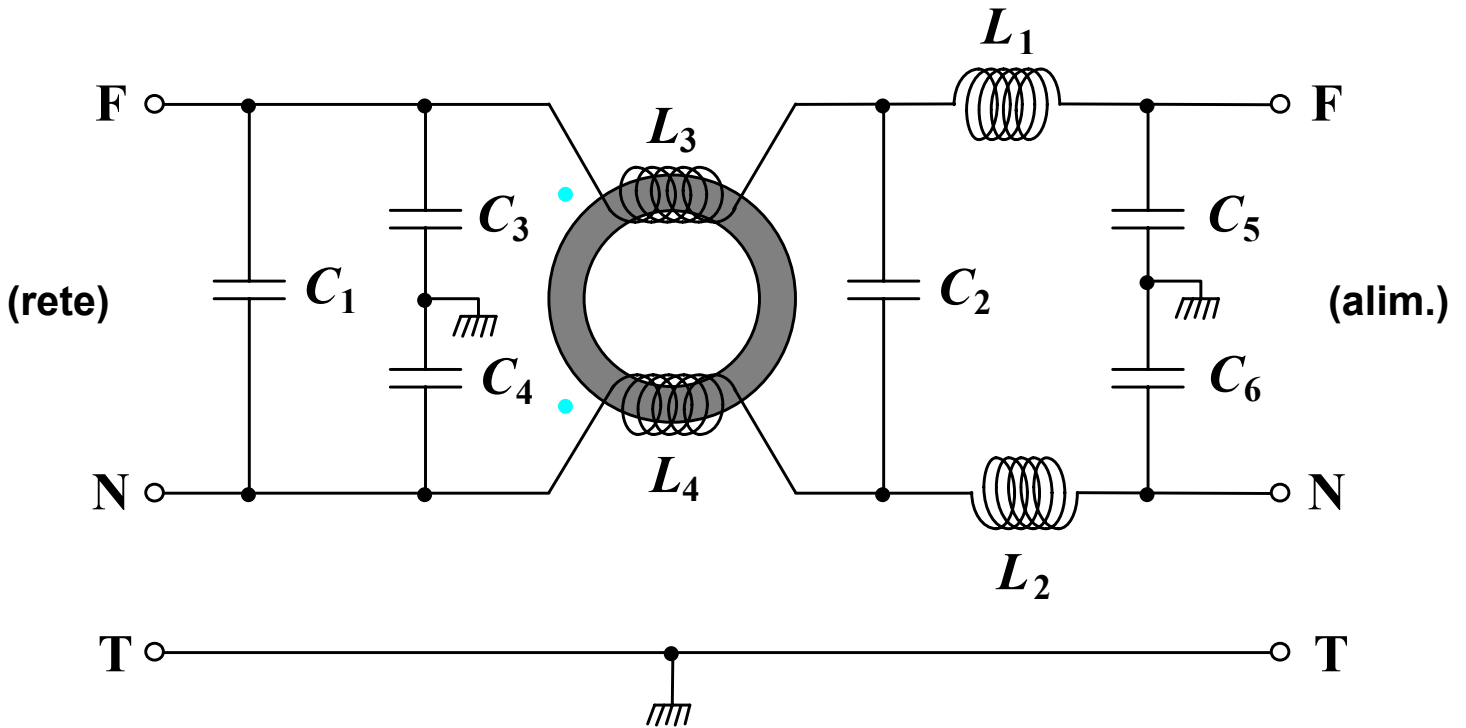

Dimensionamento di L

$$\Delta I_L^+ = \frac{V_i - V_{out}}{L} \delta T \delta = \frac{V_{out}}{V_i}$$

$$\Downarrow$$

$$L = \frac{(V_i - V_{out}) \delta T}{\Delta I_L^+} = \frac{(V_i - V_{out}) \frac{V_{out}}{V_i} T}{\Delta I_L^+}$$

$$\Downarrow$$

$$\Delta I_L^+ = k I_{L,m} = k I_{out} \Rightarrow L = \frac{(V_i - V_{out})}{k I_{out}} \cdot \frac{V_{out}}{V_i} \cdot \frac{1}{f}$$

(tipicamente si sceglie $k = 0,4$)

Dimensionamento di C

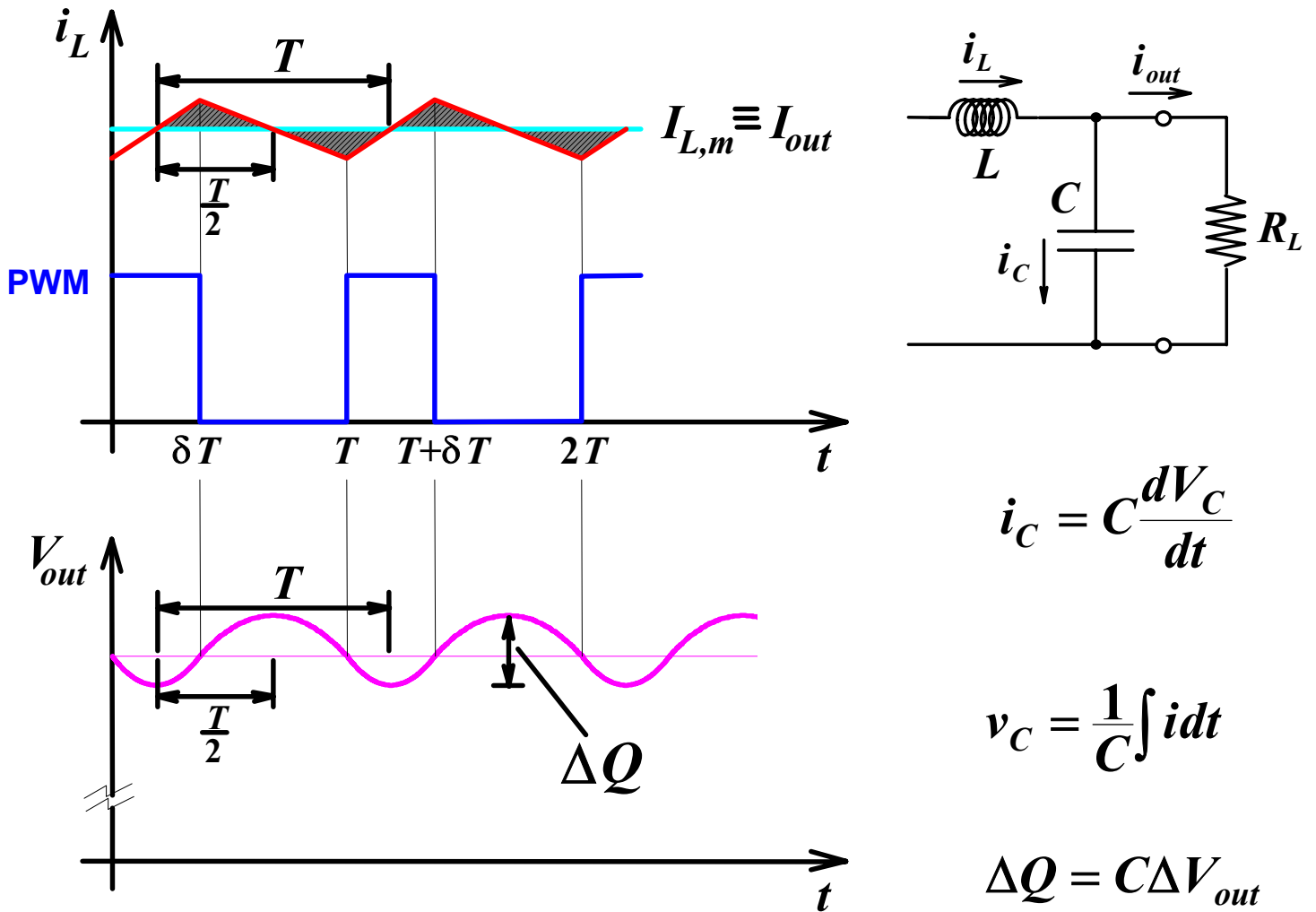

$$\Delta Q = \frac{T}{2} \frac{\Delta I_L^+}{2} \frac{1}{2} = \frac{T}{8} \Delta I_L^+$$

$$\Delta V_{out} = \frac{\Delta Q}{C} \Rightarrow \Delta V_{out} = \frac{T \Delta I_L^+}{8C}$$

$$C = \frac{\Delta Q}{\Delta V_{out}} = \frac{1}{\Delta V_{out}} \cdot \frac{T \Delta I_L}{8} = \frac{k I_{out}}{8f \Delta V_{out}} = \frac{V_{out} (V_i - V_{out})}{8f^2 L V_i \Delta V_{out}}$$

Convertitore DC/DC boost (step-up)

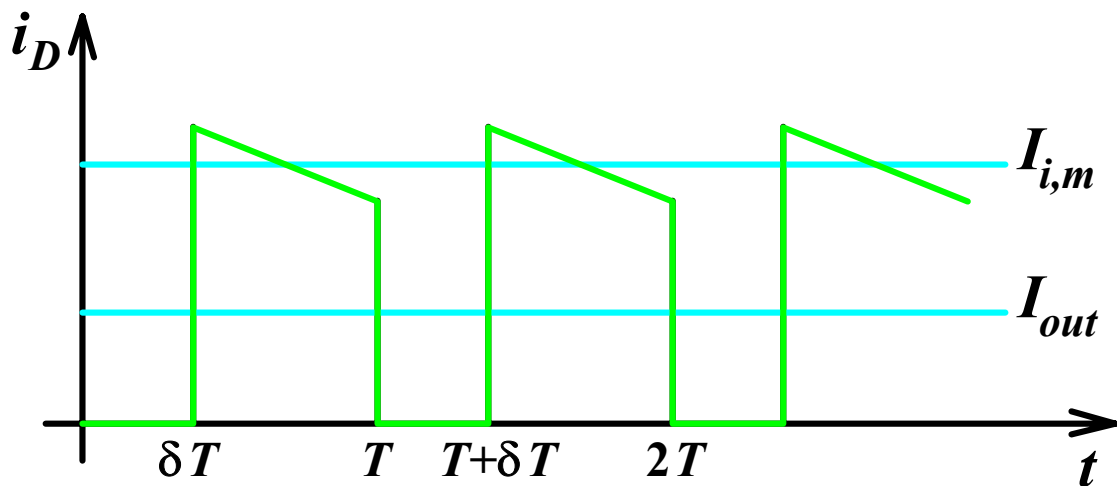
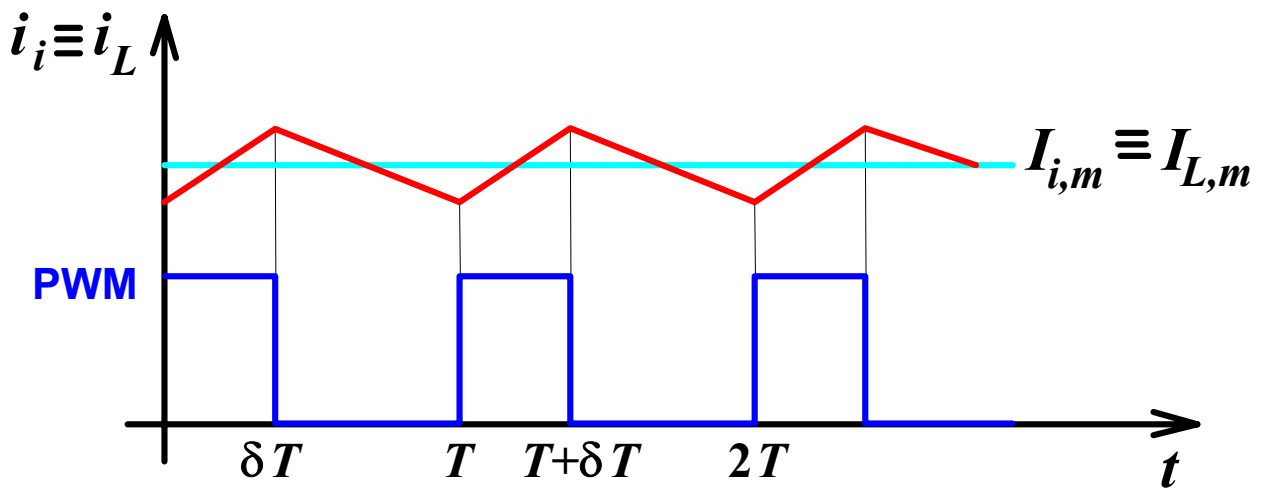
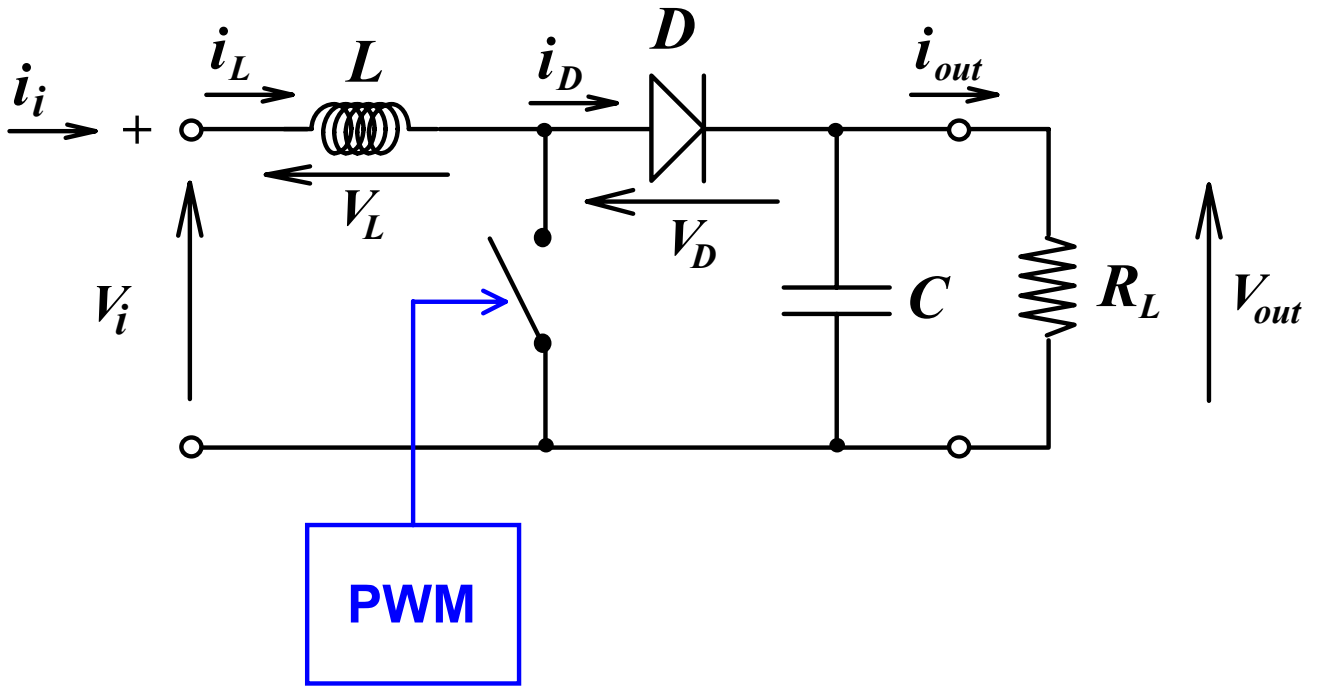

$$\Delta I_L^+ = \frac{V_i}{L} \delta T \quad \Delta I_L^- = \frac{V_{out} - V_i}{L} (1 - \delta) T$$

$$\delta V_i = (V_{out} - V_i)(1 - \delta) \Rightarrow V_{out} = \frac{V_i}{1 - \delta}$$

$$I_{i,m}(1 - \delta) T = I_{out} T \Rightarrow I_{out} = (1 - \delta) I_{i,m}$$

<i>Dimensionamento di L</i>	<i>Dimensionamento di C</i>
$\Delta I_L = \frac{(V_{out} - V_i)V_i}{f L V_{out}}$ \Downarrow $L = \frac{(V_{out} - V_i)V_i}{f \Delta I_L V_{out}}$ $I_{L,m} = I_{i,m} = \frac{I_{out} V_{out}}{V_i}$ \Downarrow $L = \frac{V_i^2 (V_{out} - V_i)}{f k I_{out} V_{out}^2}$ con $\Delta I_L = k I_{L,m}$	<p data-bbox="895 1084 1390 1133"><i>In prima approssimazione</i></p> $\Delta V_{out} = \frac{I_{out} \delta T}{C}$ $\Delta V_{out} = \frac{I_{out}}{C} \left(T - \frac{V_i}{V_{out}} T \right)$ $= \frac{I_{out} (V_{out} - V_i)}{f C V_{out}}$ $C = \frac{I_{out} (V_{out} - V_i)}{f V_{out} \Delta V_{out}}$

Convertitore DC/DC invertente

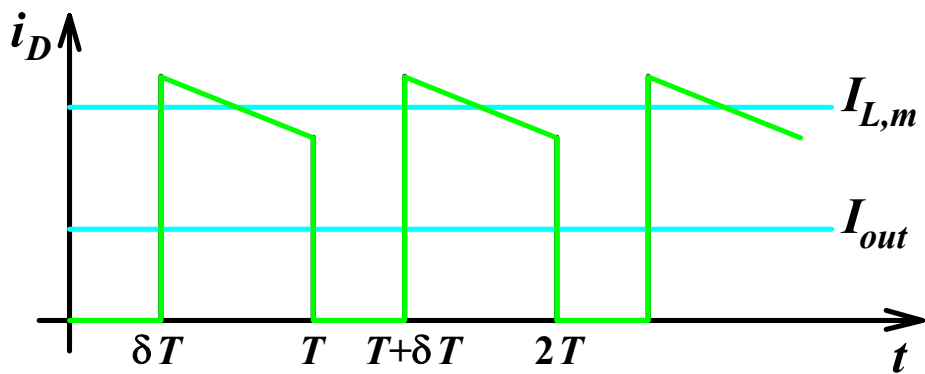
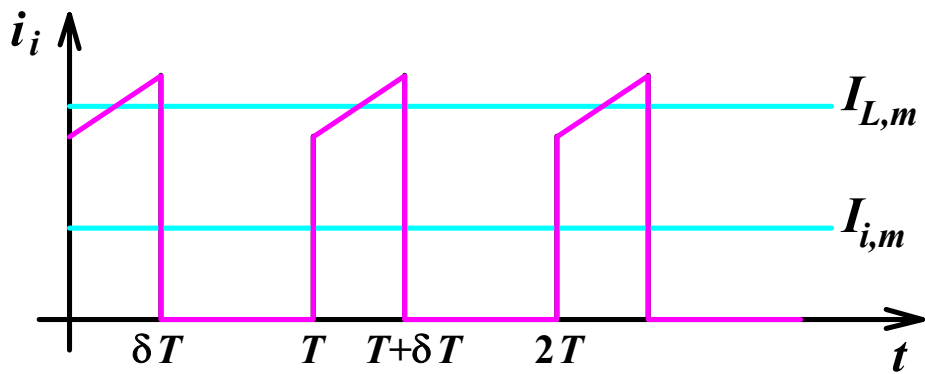
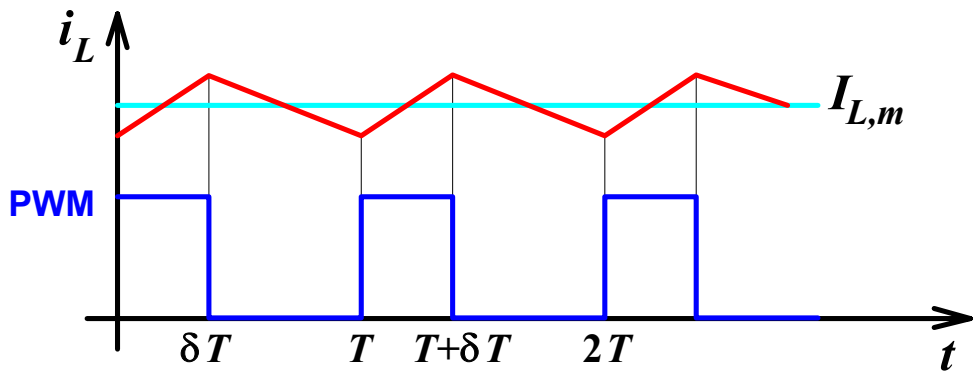
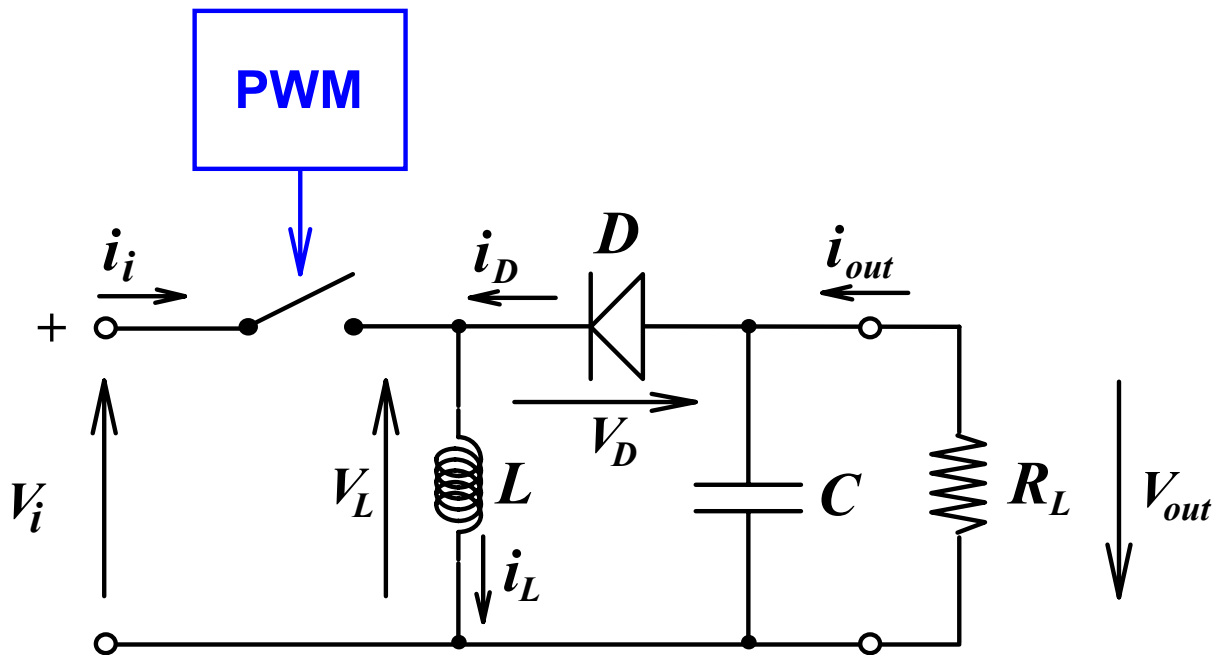

$$\Delta I_L^+ = \frac{V_i}{L} \delta T$$

$$\Delta I_L^- = \frac{V_{out}}{L} (1 - \delta) T$$

$$\frac{V_i}{L} \delta T = \frac{V_{out}}{L} (1 - \delta) T \Rightarrow$$

$$V_{out} = V_i \frac{\delta}{1 - \delta}$$

$$I_{i,m} \cdot T = I_{L,m} \cdot \delta T$$

$$\Rightarrow$$

$$I_{out} = I_{i,m} \frac{1 - \delta}{\delta}$$

$$I_{out} \cdot T = I_{L,m} \cdot (1 - \delta) T$$

<i>Dimensionamento di L</i>	<i>Dimensionamento di C</i>
$\Delta I_L = \frac{V_i V_{out}}{f L (V_i + V_{out})}$ \Downarrow $L = \frac{V_i V_{out}}{f \Delta I_L (V_i + V_{out})}$ $I_{L,m} = \frac{I_{out} (V_i + V_{out})}{V_i}$ \Downarrow $L = \frac{V_i^2 V_{out}}{f k I_{out} (V_i + V_{out})^2}$ <p>con $\Delta I_L = k I_{L,m}$</p>	<p><i>In prima approssimazione</i></p> $\Delta V_{out} = \frac{I_{out} \delta T}{C}$ $\Delta V_{out} = \frac{I_{out}}{C} \left(\frac{V_{out}}{V_i + V_{out}} T \right)$ $= \frac{I_{out} V_{out}}{f C (V_i + V_{out})}$ $C = \frac{I_{out} V_{out}}{f \Delta V_{out} (V_i + V_{out})}$

Convertitore DC/DC flyback (ad interdizione)

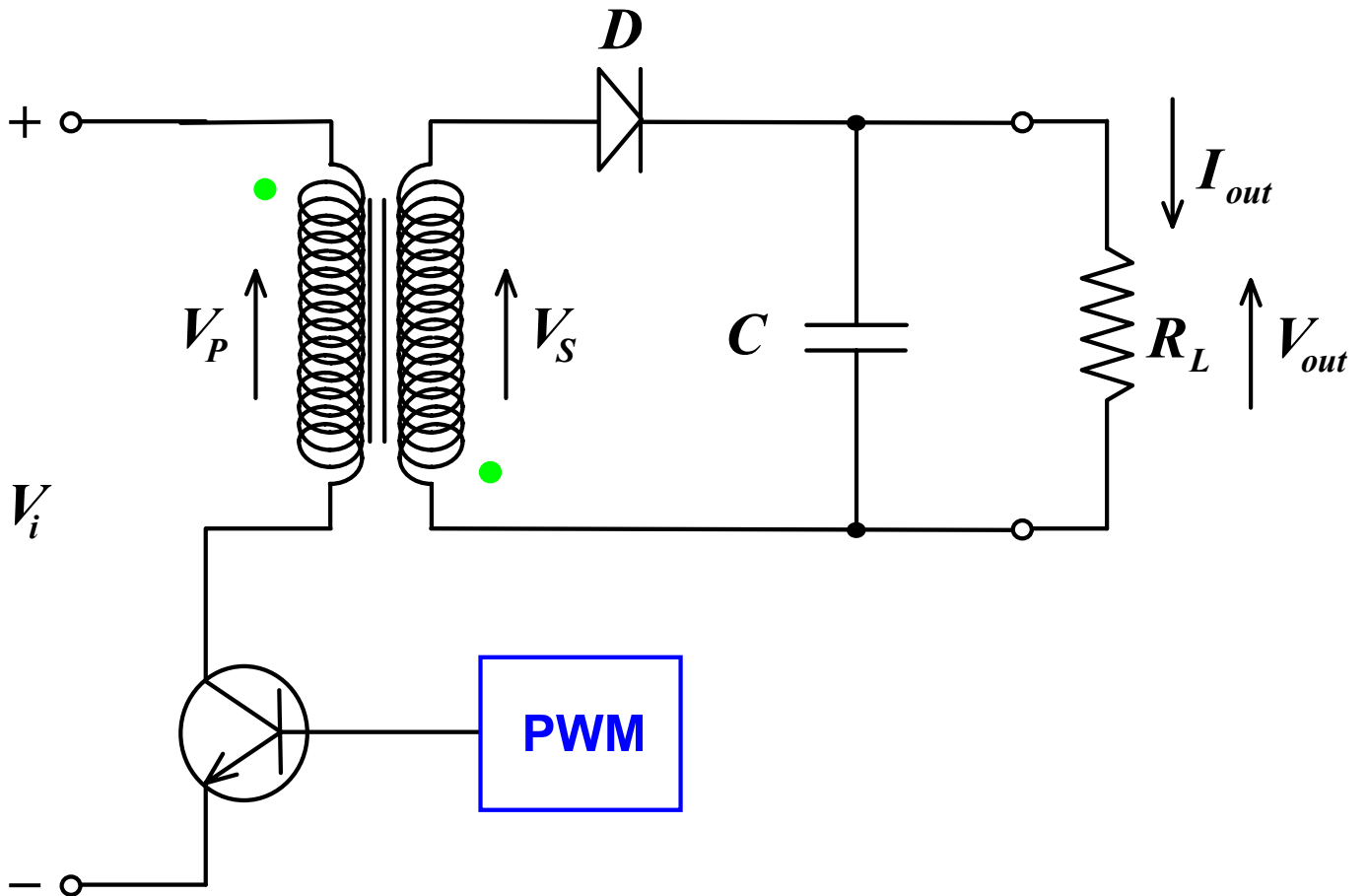

$$\frac{V_P}{V_S} = \frac{n_1}{n_2} = n = \frac{i_S}{i_P}$$

Modello equivalente del trasformatore

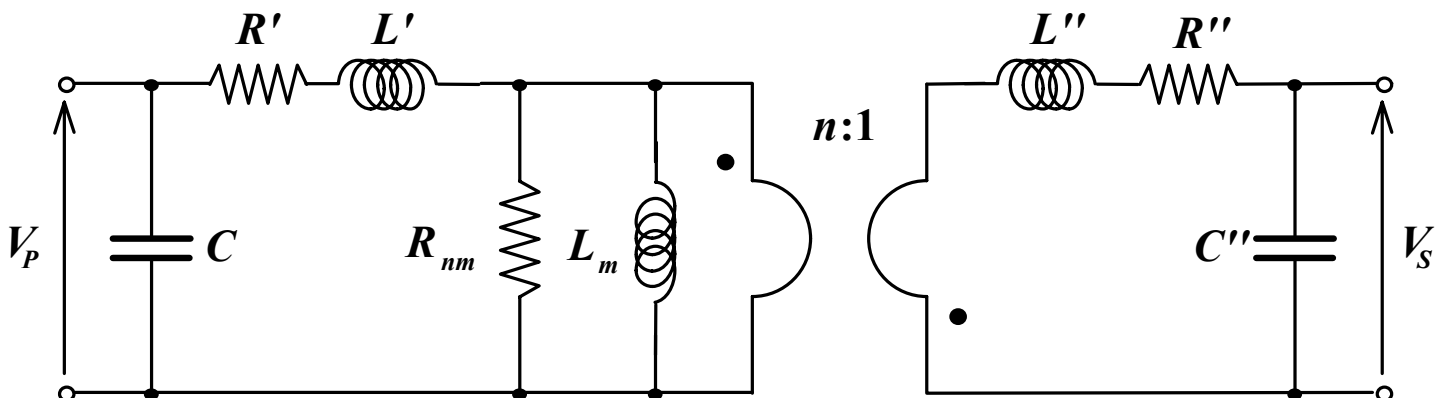

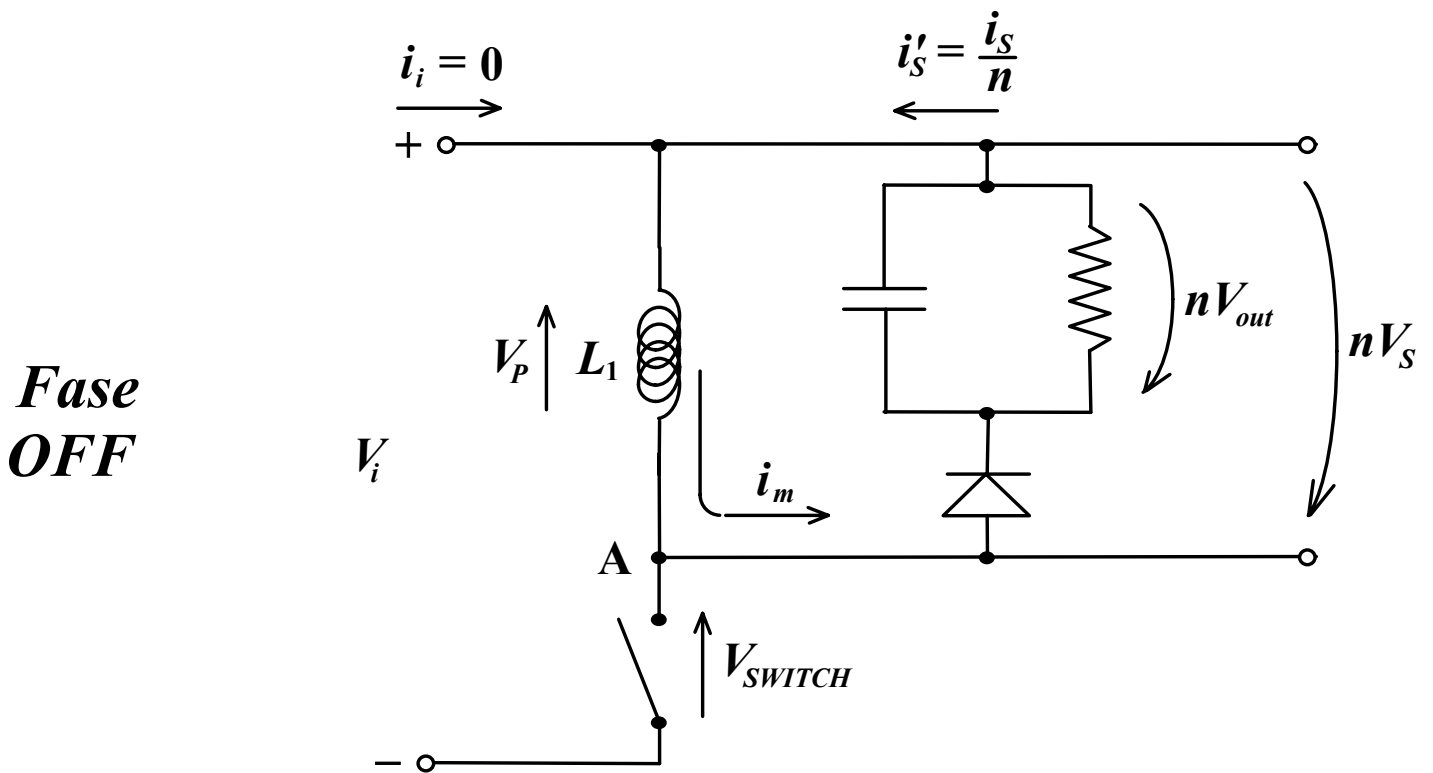
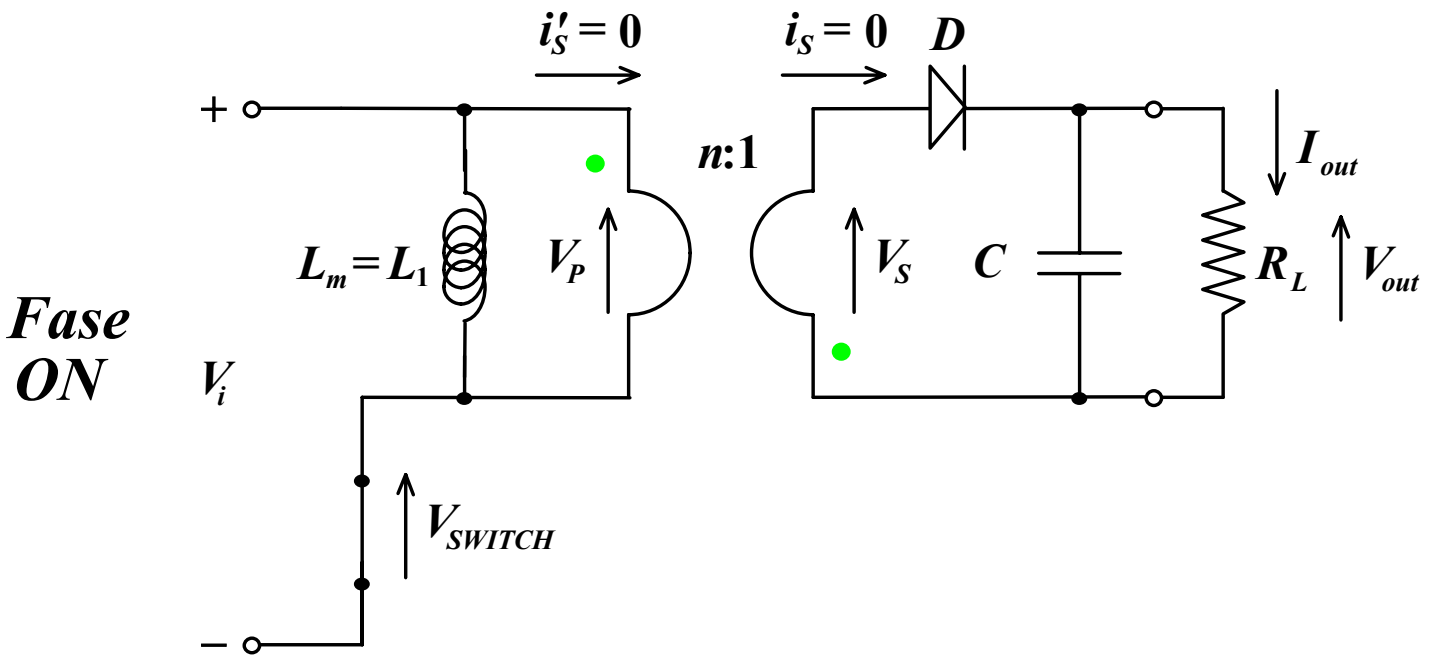

Fase ON $\Delta I_m^+ = \frac{V_i}{L_1} \delta T$

Fase OFF $\Delta I_m^- = \frac{nV_{out}}{L_1} (1 - \delta) T$

$\Delta I_m^+ = \Delta I_m^-$
 \Rightarrow

$V_{out} = \frac{V_i}{n} \frac{\delta}{1 - \delta}$

Funzionamento continuo (onda trapezoidale)

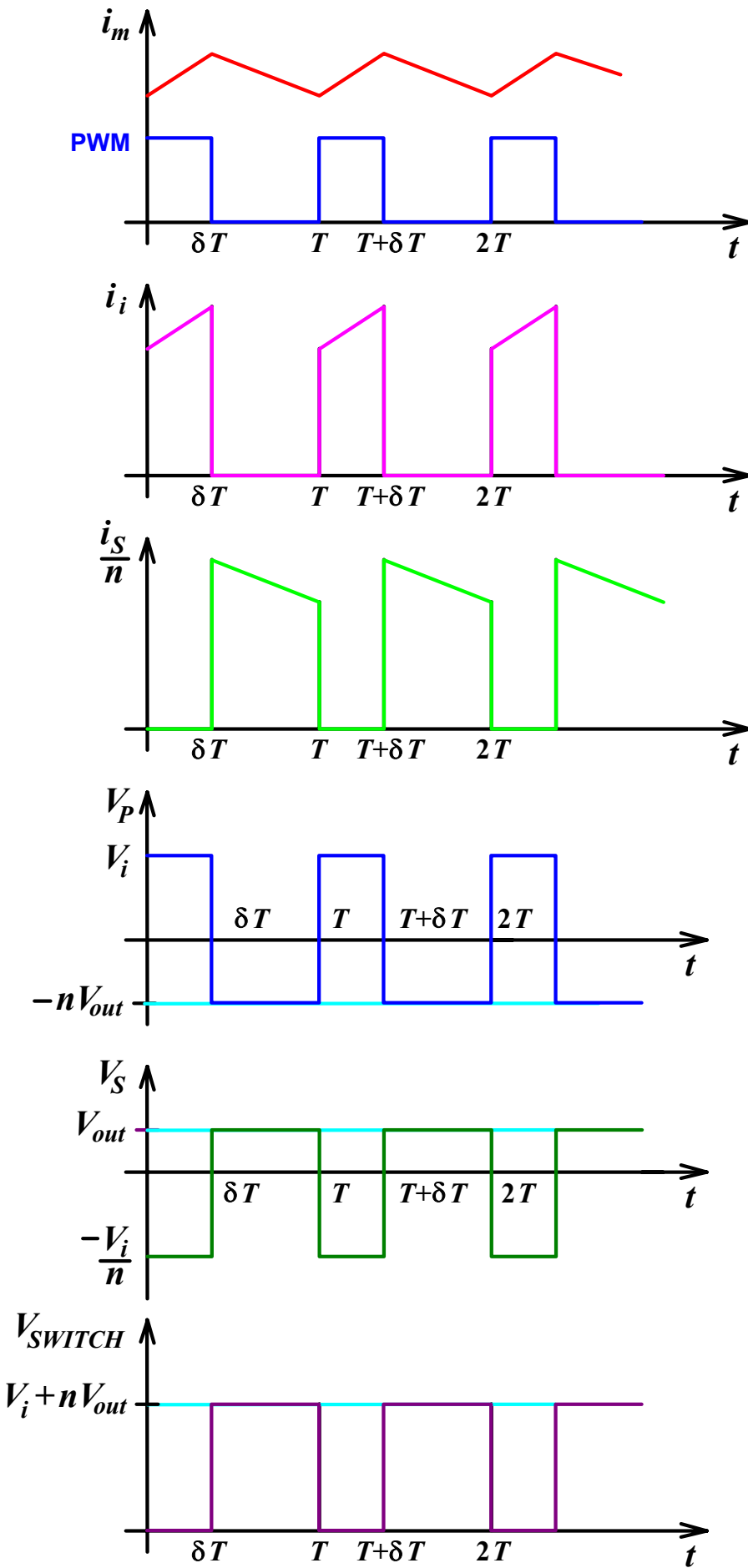

Funzionamento discontinuo (onda triangolare)

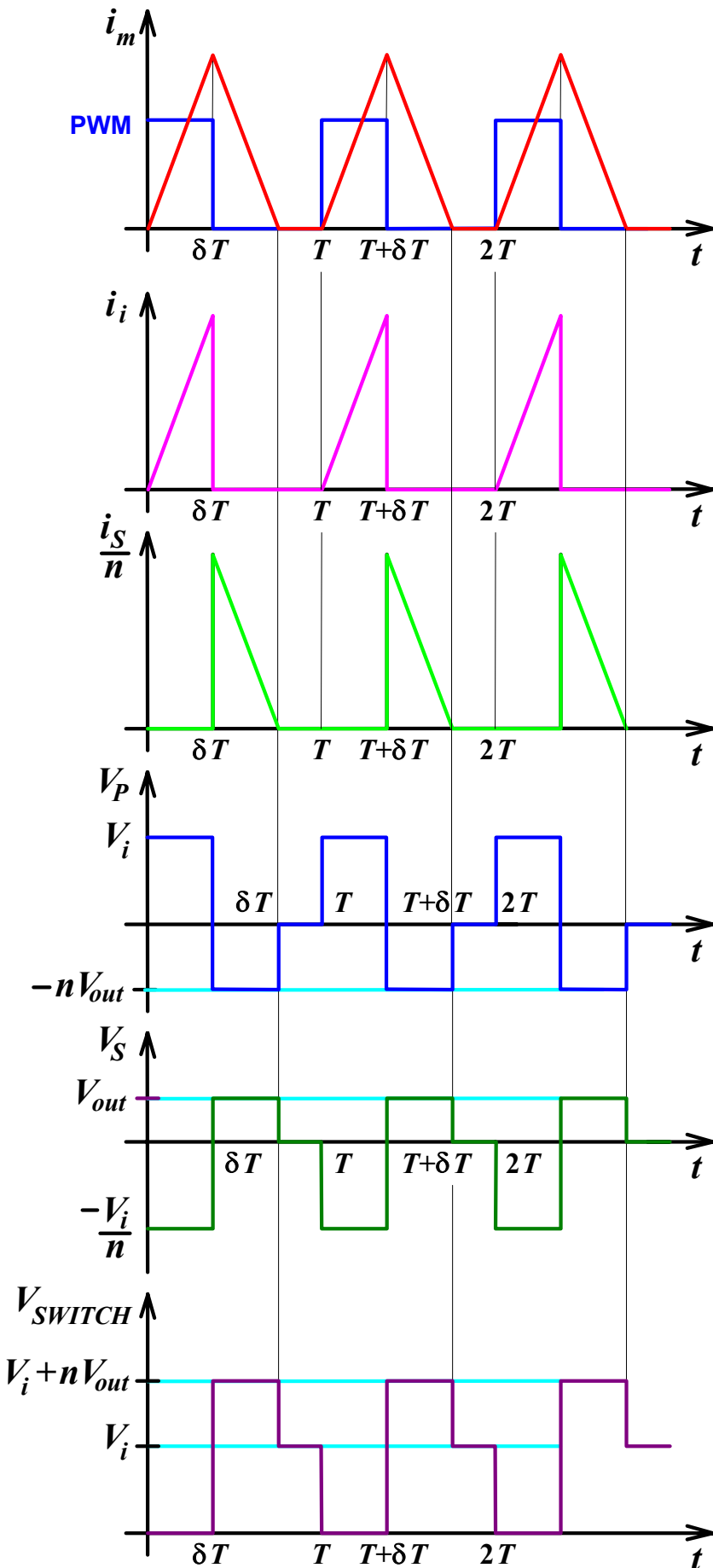

$$\frac{V_{out}}{V_i} = ?$$

$$E = \frac{1}{2} L_1 I_m^2$$

$$I_m = \frac{V_i}{L_1} \delta T$$

$$P = \frac{1}{2} L_1 \left(\frac{\delta V_i}{L_1} \right)^2 \frac{T^2}{T}$$

(SORGENTE PRIMARIA)

$$P_L = \frac{V_{out}^2}{R_L} \quad (\text{AL CARICO})$$

$$V_{out} = \delta V_i \sqrt{\frac{R_L}{2L_1} T}$$

$$V_{SW_{max}} = V_i + nV_{out}$$

Convertitore DC/DC forward (a conduzione)

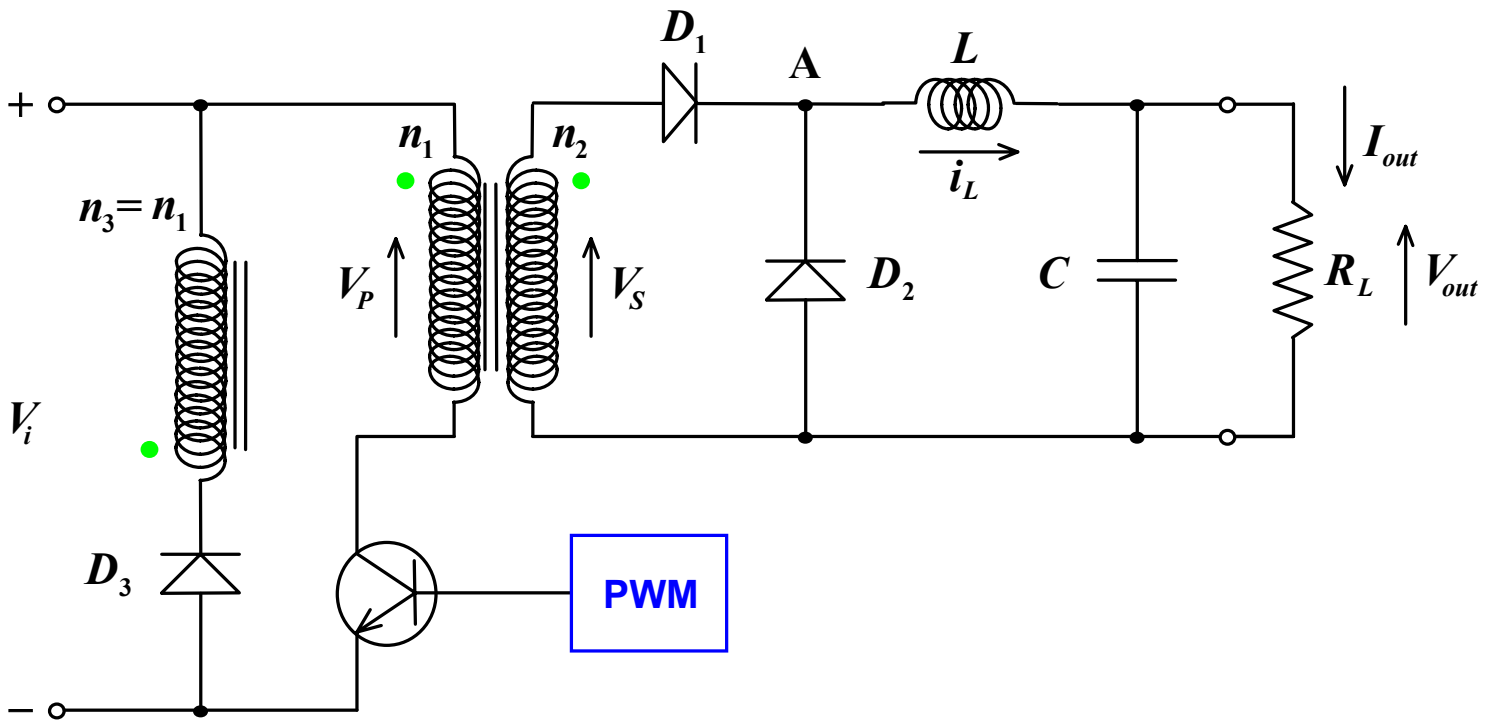

Fase ON

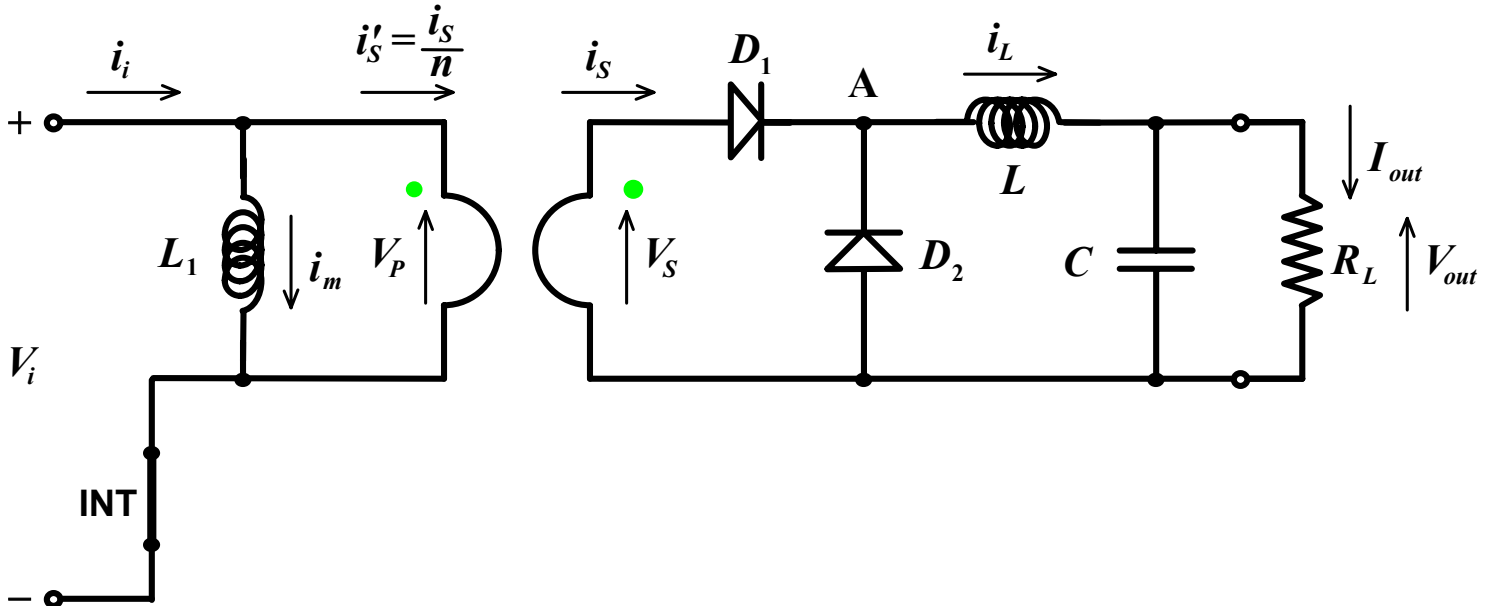

$$i_S = i_L i_i = i_m + \frac{i_S}{n} = i_i = \frac{V_i}{L} t + \frac{1}{n} \left(\frac{V_i}{n} - V_{out} \right) \frac{1}{L} t + I_i(0)$$

$$\Delta I_L^+ = \left(\frac{V_i}{n} - V_{out} \right) \frac{1}{L} \delta T$$

Fase OFF

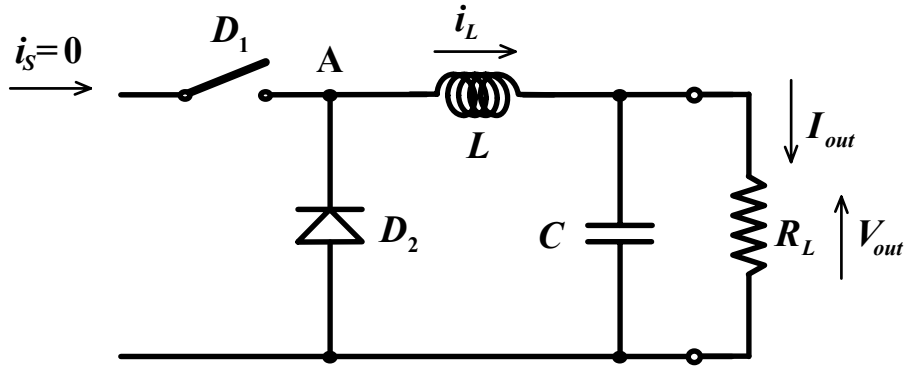
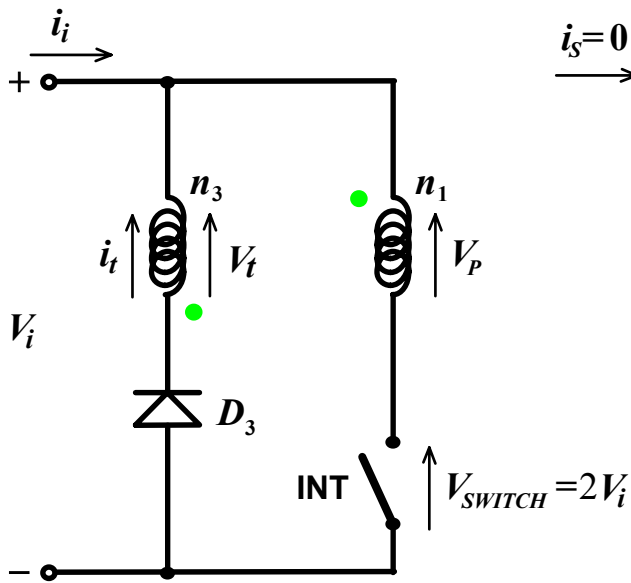

$$i_m = i_t$$

$$V_t = V_\gamma + V_i \cong V_i \quad V_p = -V_t = -V_i \quad V_s = -\frac{V_i}{n}$$

$$\Delta I_L^- = \frac{V_{out}}{L} (1 - \delta) T \Rightarrow \Delta I_L^+ = \Delta I_L^- \Rightarrow$$

$$V_{out} = \frac{\delta}{n} V_i$$

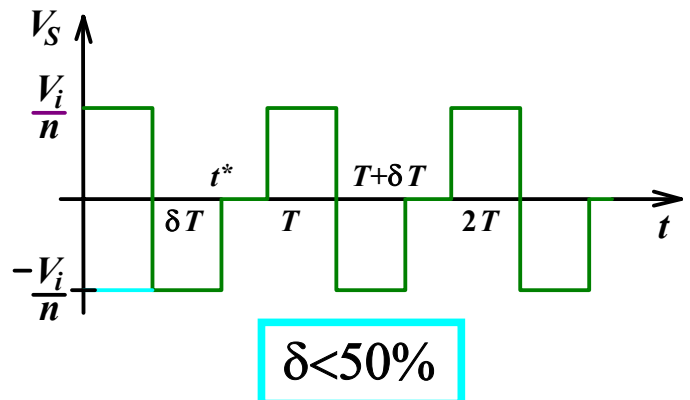
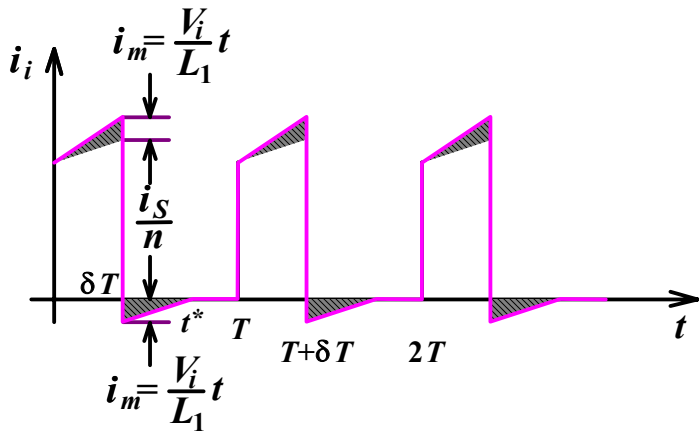

$$\delta < 50\%$$

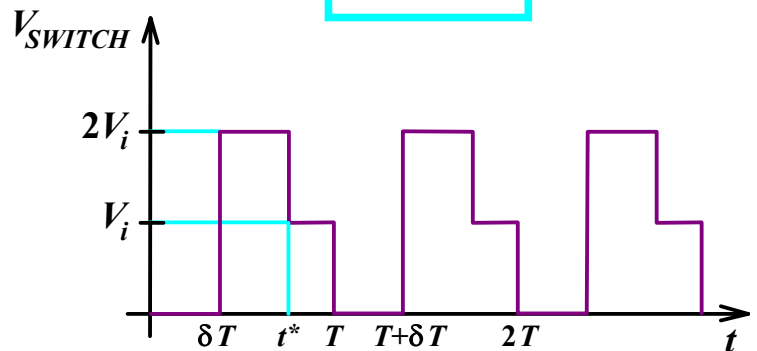
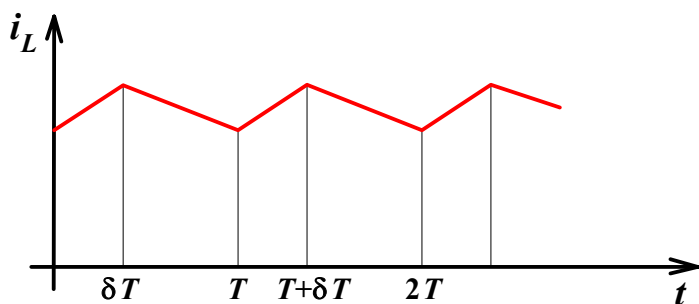

Convertitore push-pull (in controfase) [500W]

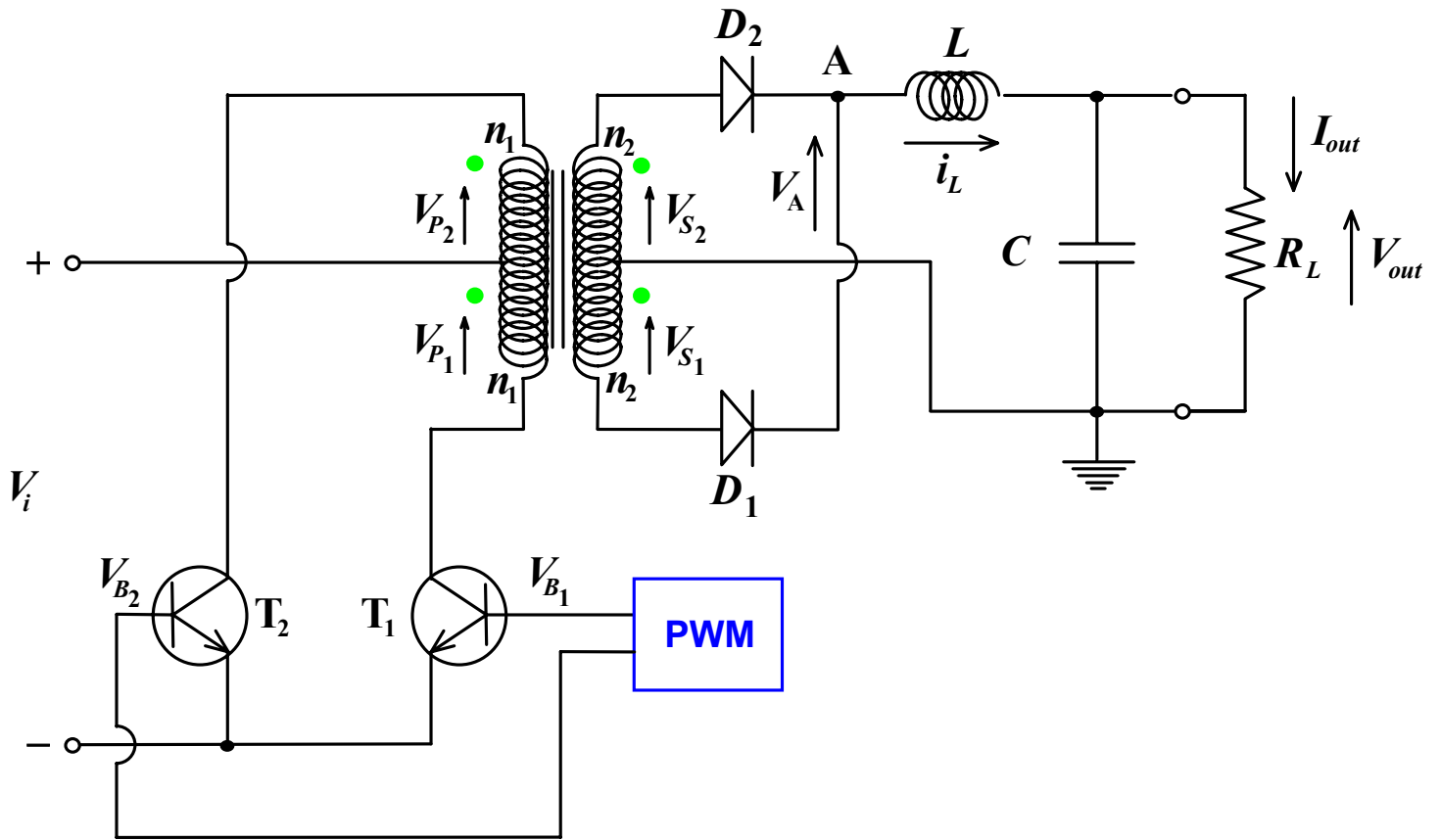

Fasi 1,3

$$i_L = \left(\frac{V_i}{n} - V_{out} \right) t + I_L(0) \Rightarrow \Delta I_L^+ = \left(\frac{V_i}{n} - V_{out} \right) \delta T$$

Fasi 2,4
$$i_L = \frac{V_{out}}{L} t' + I'_L(0) \Rightarrow \Delta I_L^- = \frac{V_{out}}{L} \left(\frac{T}{2} - \delta T \right)$$

$$\Delta I_L^+ = \Delta I_L^- \Rightarrow \frac{V_i}{n} \delta - \delta V_{out} = \frac{V_{out}}{2} - \delta V_{out}$$

⇓

$$V_{out} = \frac{2}{n} \delta V_i$$

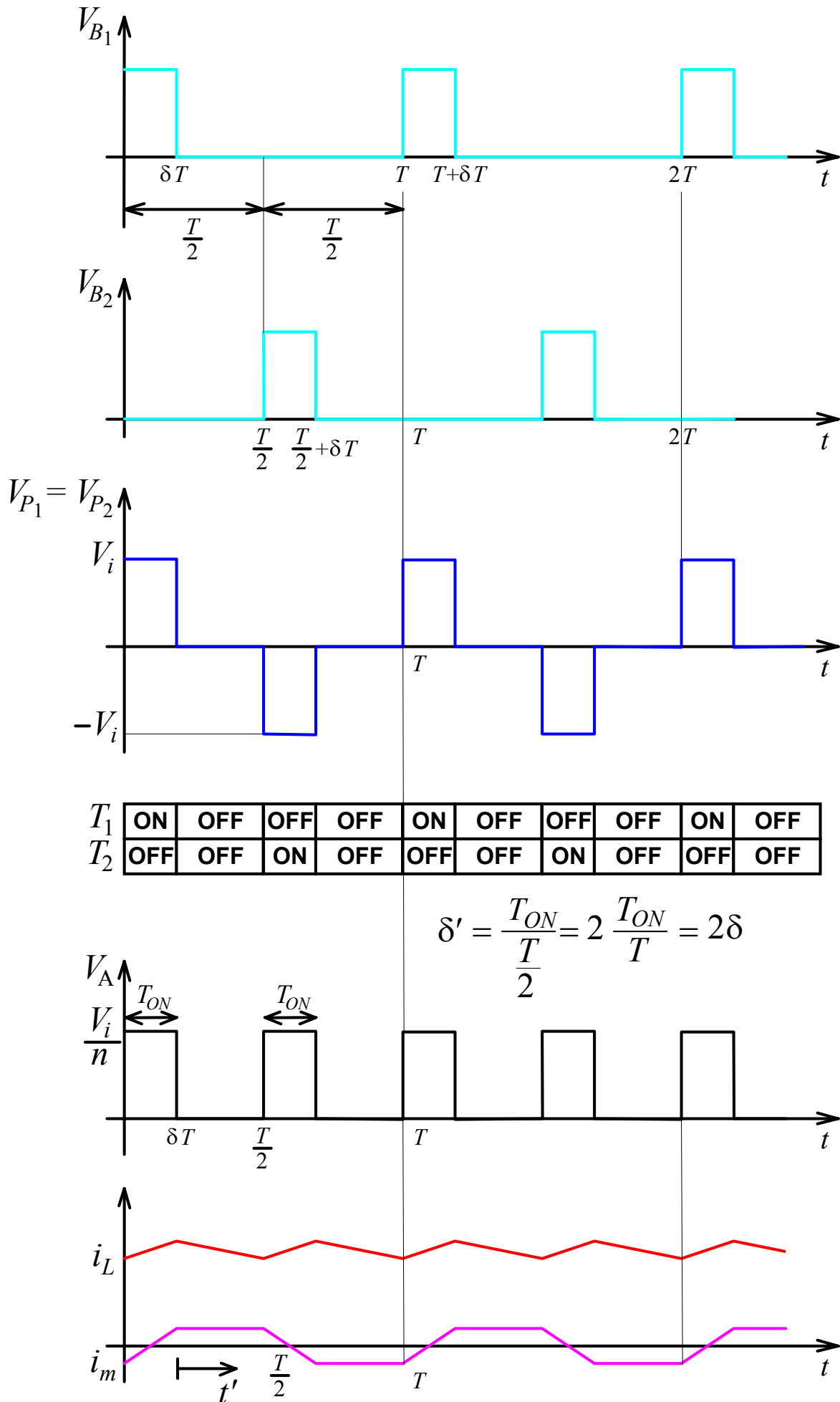

Convertitore a semiponte [$> 500W$]

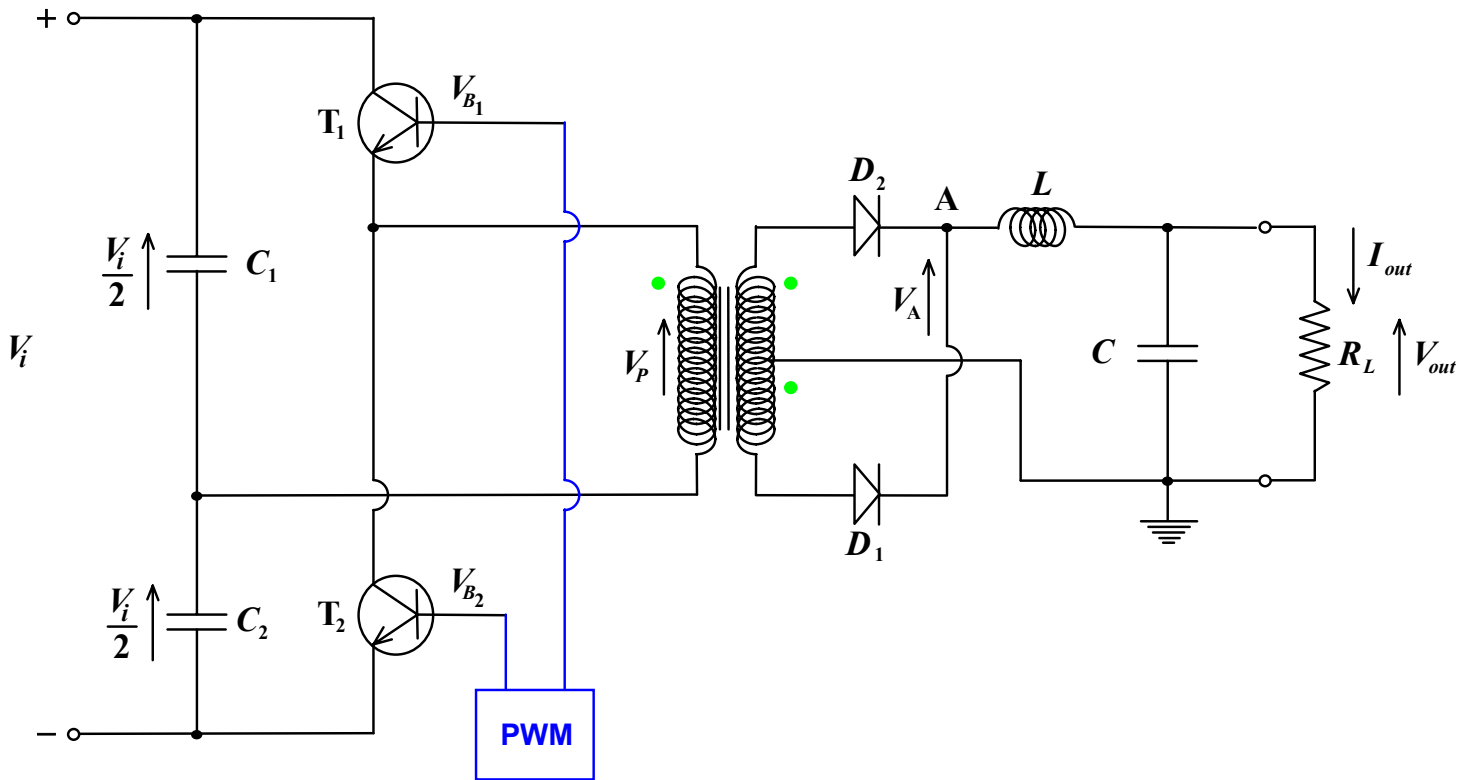

$$V_{out} = \frac{V_i}{n} \delta$$

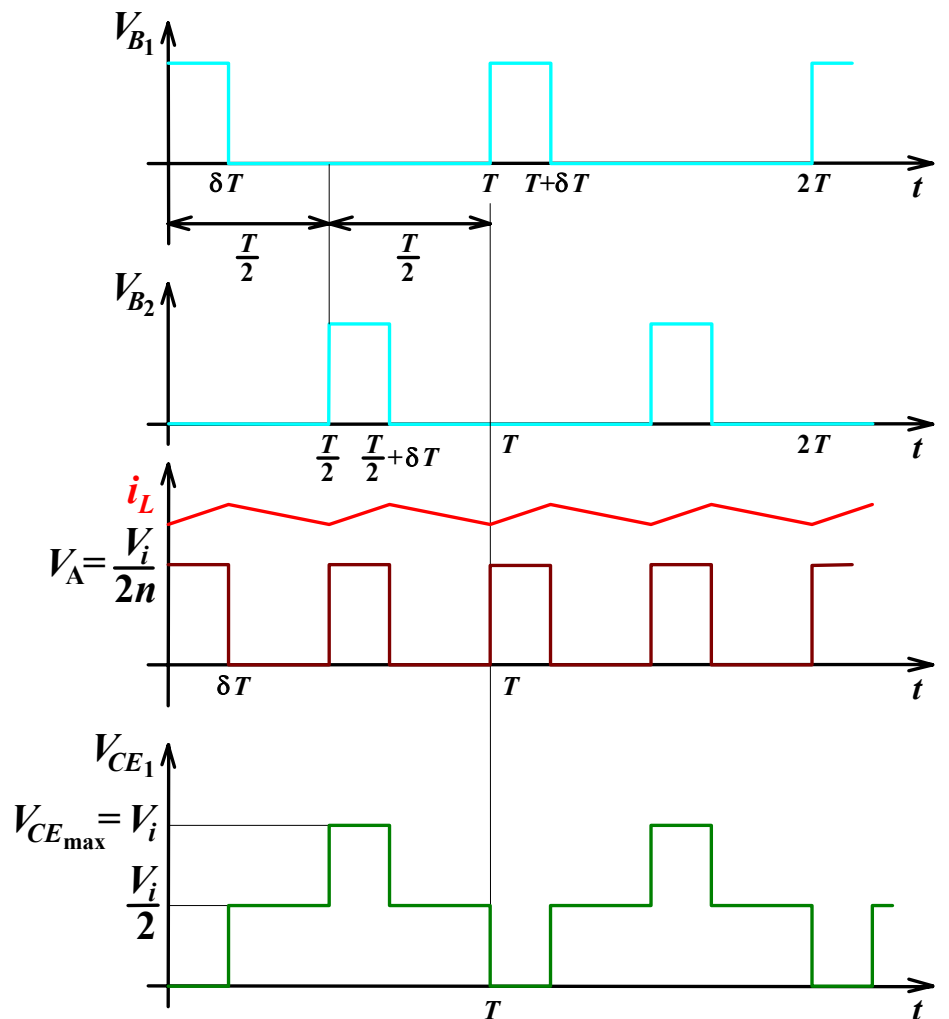

Convertitore a ponte intero [$\leq 2\text{kW}$]

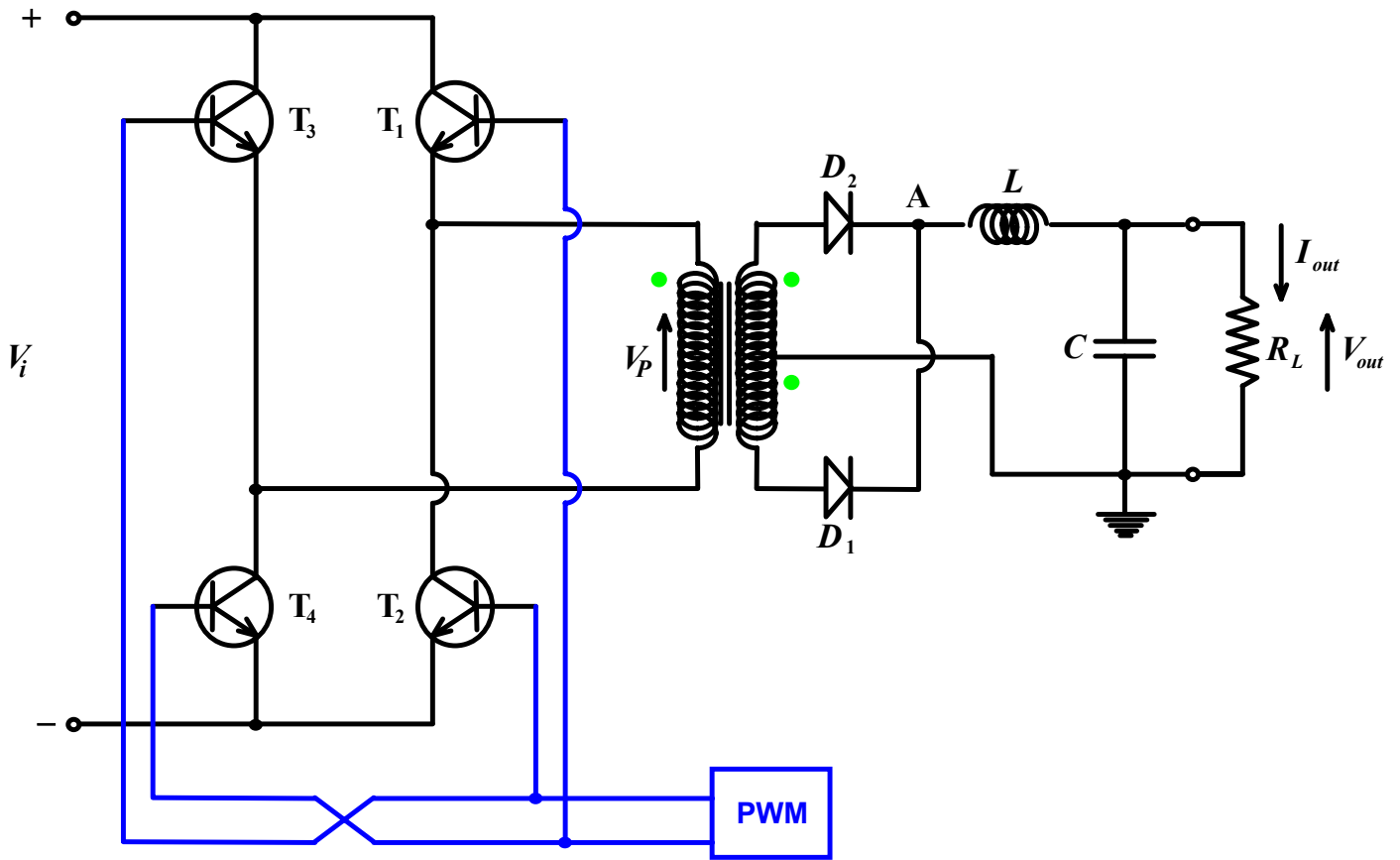

<i>Fase</i>	<i>Transistore 1</i>	<i>Transistore 2</i>	<i>Transistore 3</i>	<i>Transistore 4</i>
1	ON	OFF	OFF	ON
2	OFF	OFF	OFF	OFF
3	OFF	ON	ON	OFF
4	OFF	OFF	OFF	OFF

$$V_{out} = \frac{2}{n} \delta V_i$$

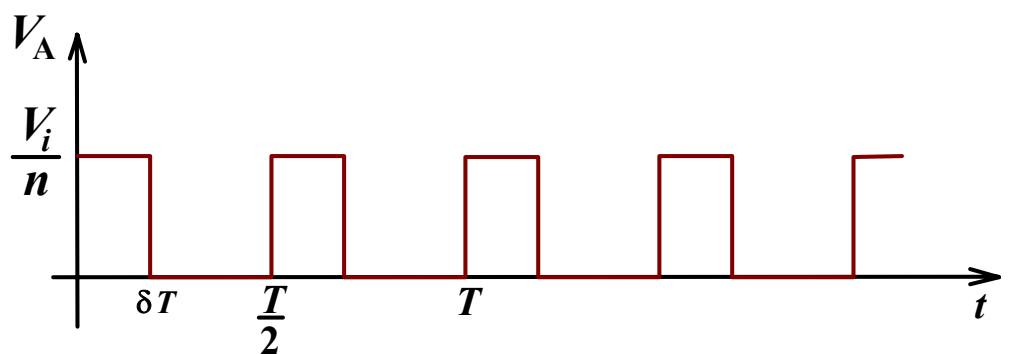

Alimentatore a risonanza

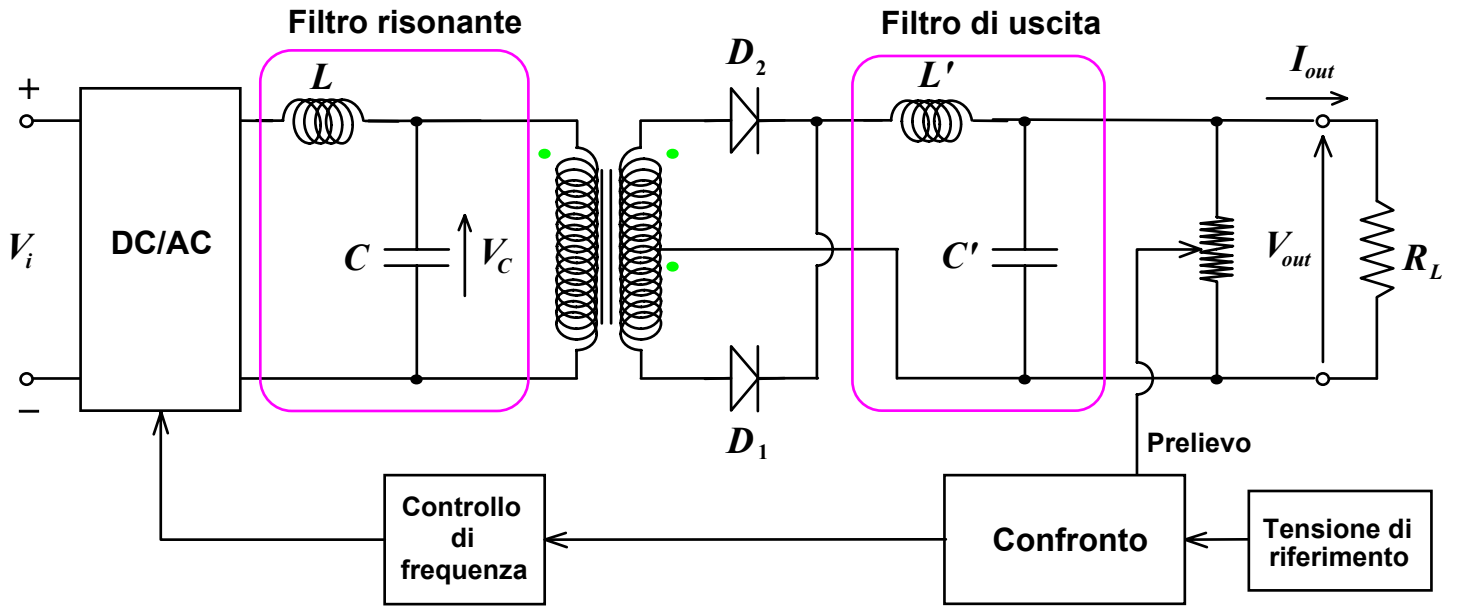

L, C filtro risonante

L', C' filtro di uscita

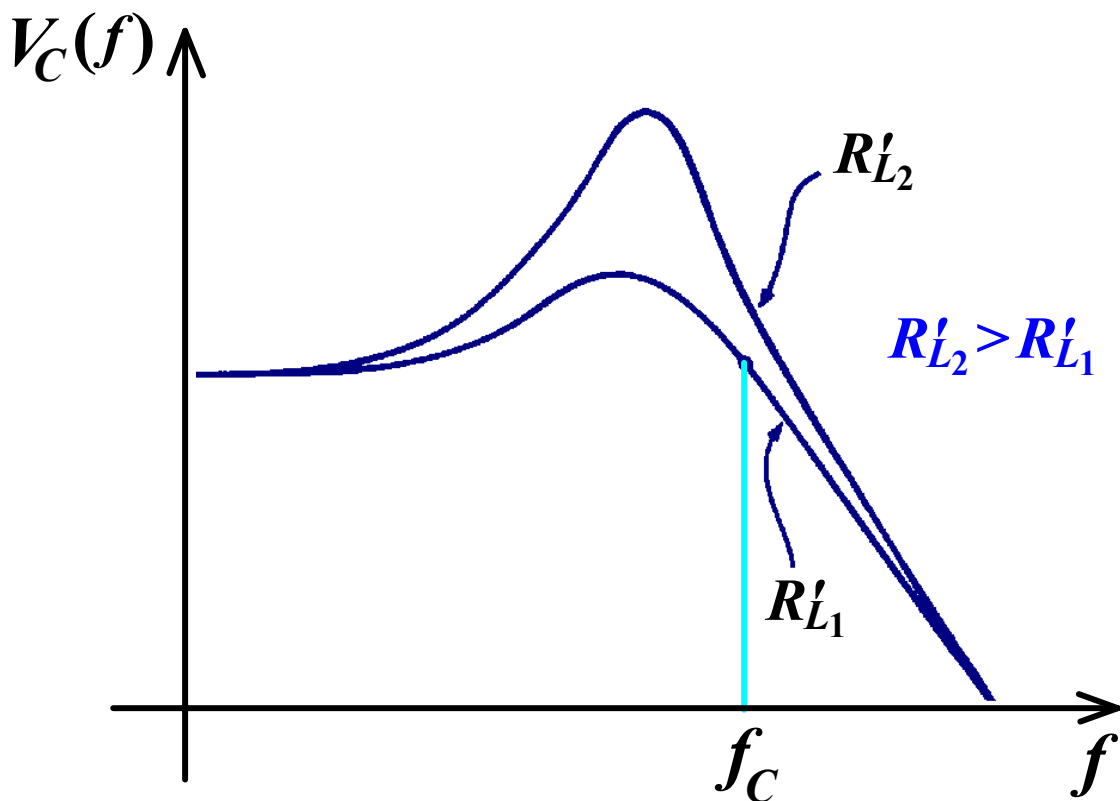

SMPS con uscite multiple

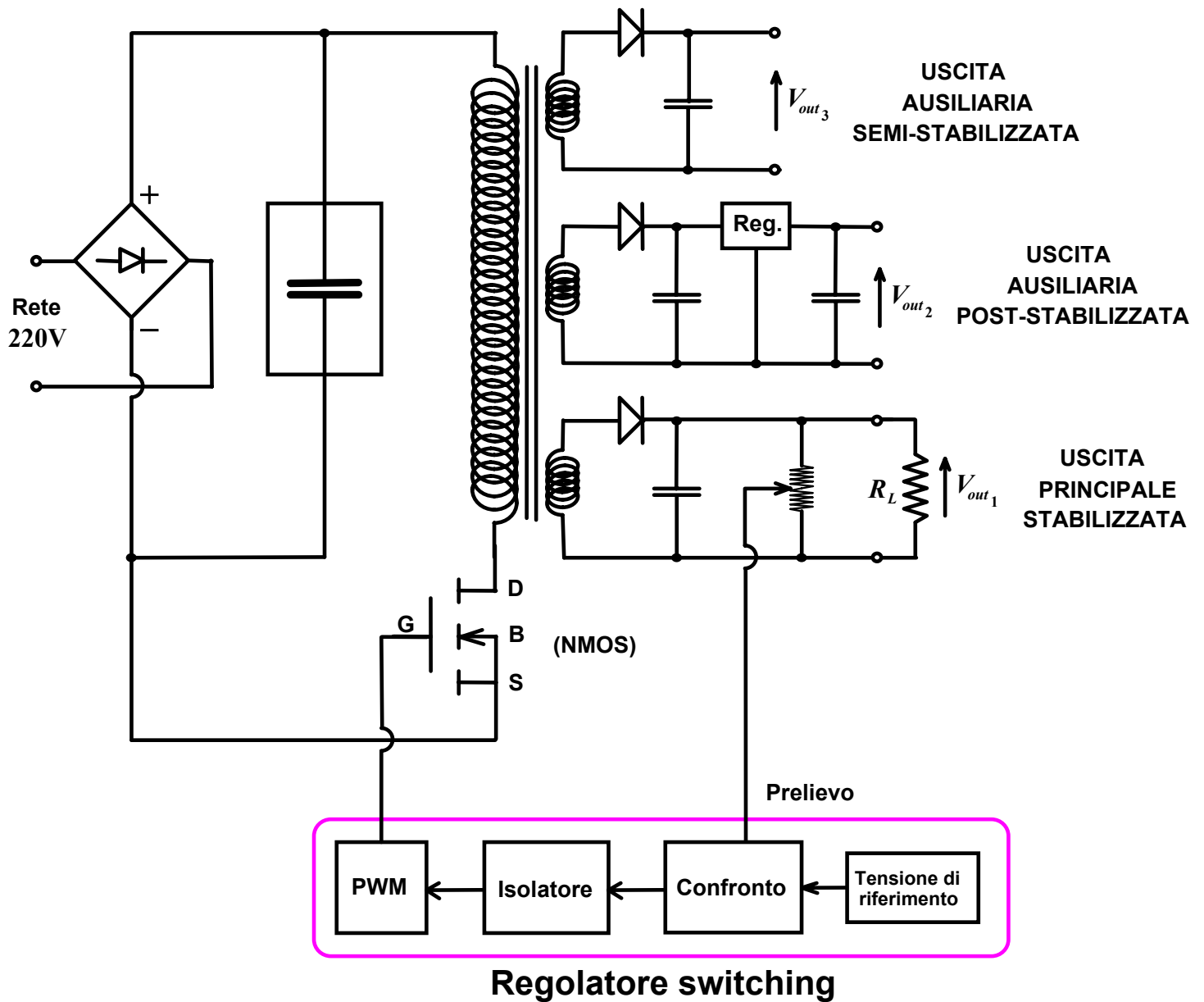

Caratteristiche principali:

- buona regolazione nei confronti delle variazioni della tensione di rete;
- variazioni della tensione sulle uscite ausiliarie a seguito di variazioni di carico sull'uscita principale (effetto della cross-regulation).

Risposta ai transitori

Tecniche utilizzate

- *Feedforward*
- *Current mode*
- *Soft start*

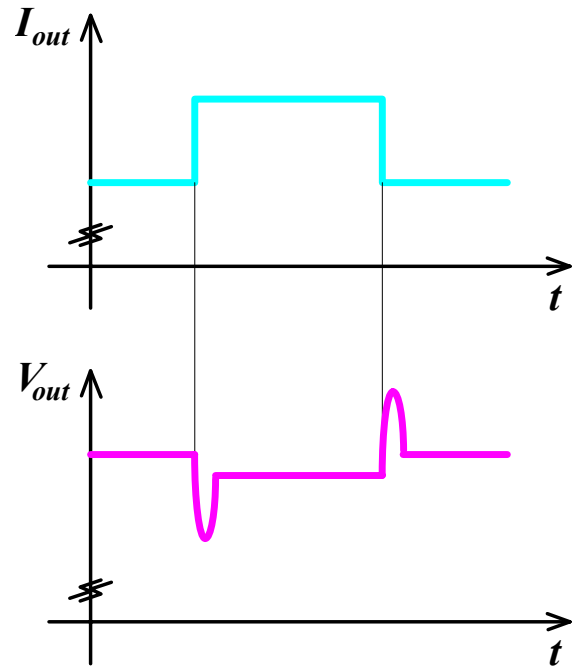

UPS (Uninterruptible Power Supply)

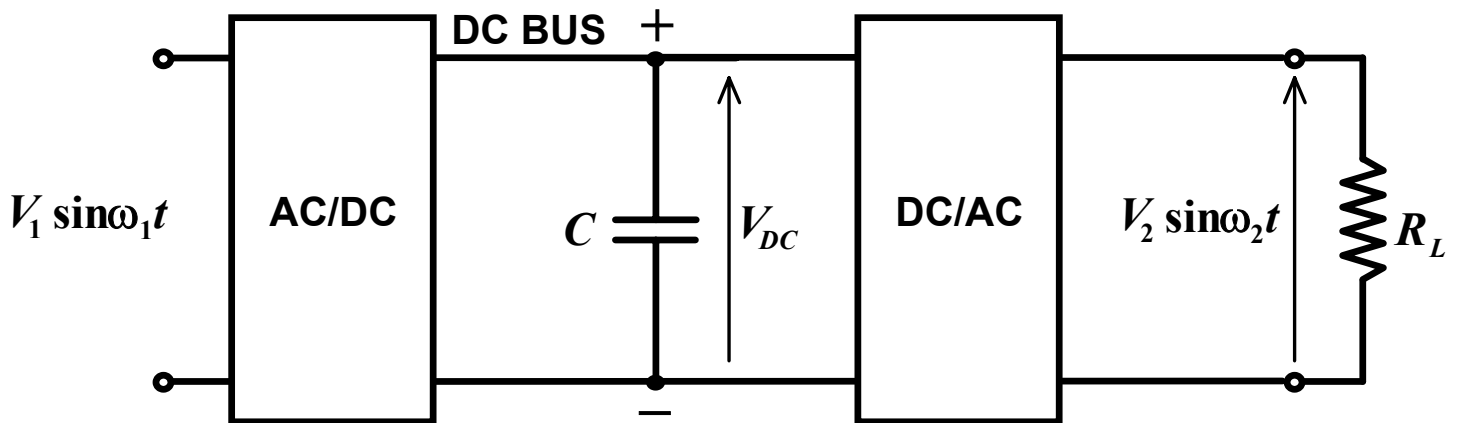

OVP
(Over Voltage Protection)

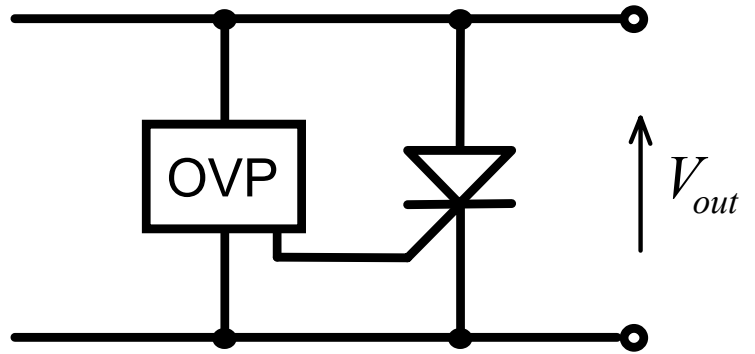

Scelta dei dispositivi passivi ed attivi

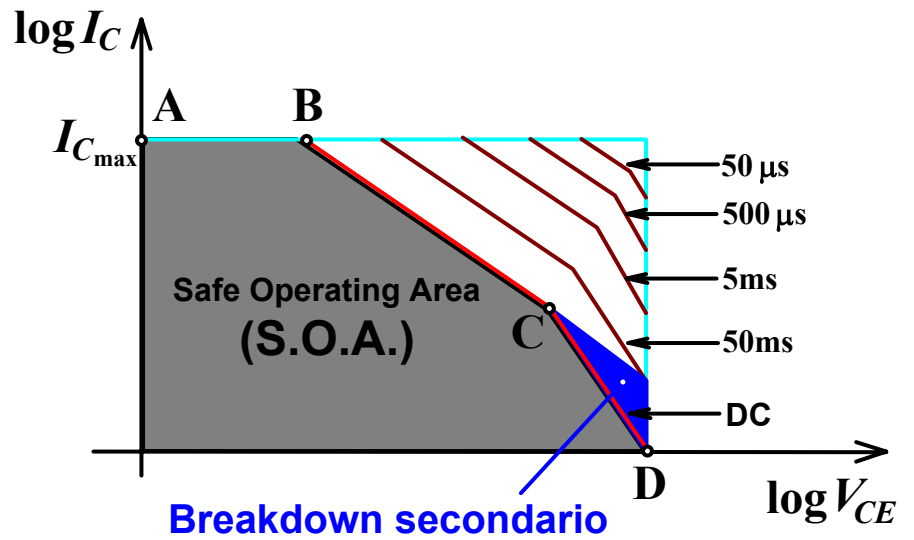
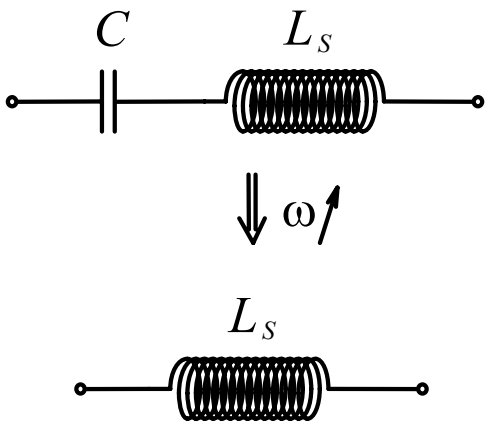

Parametri di interesse:

ESR=Equivalent Series Resistance

ESL=Equivalent Series Inductance

Breakdown secondario

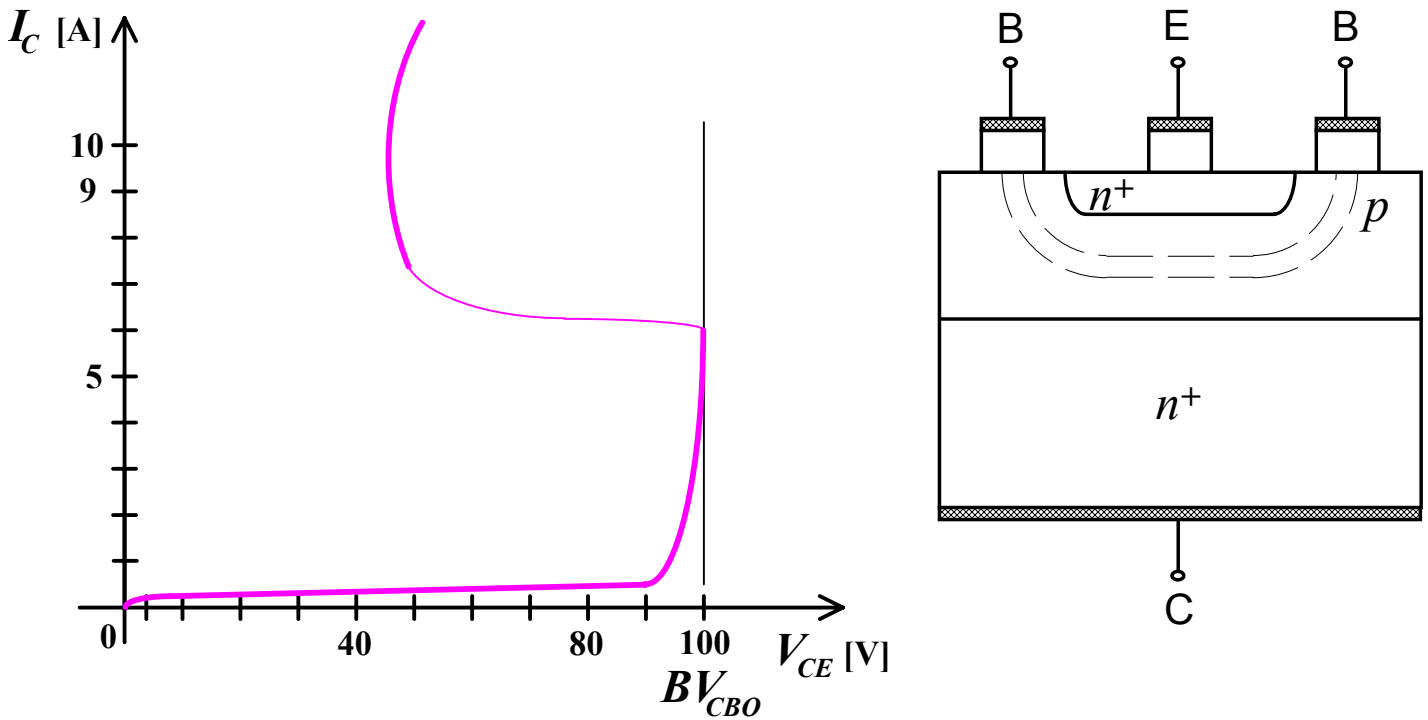

Per evitare l'effetto di **focalizzazione della corrente** le connessioni interne della base e dell'emettitore sono fatte a pettine interdigitale.

Circuiti di pilotaggio

pilotaggio di BJT

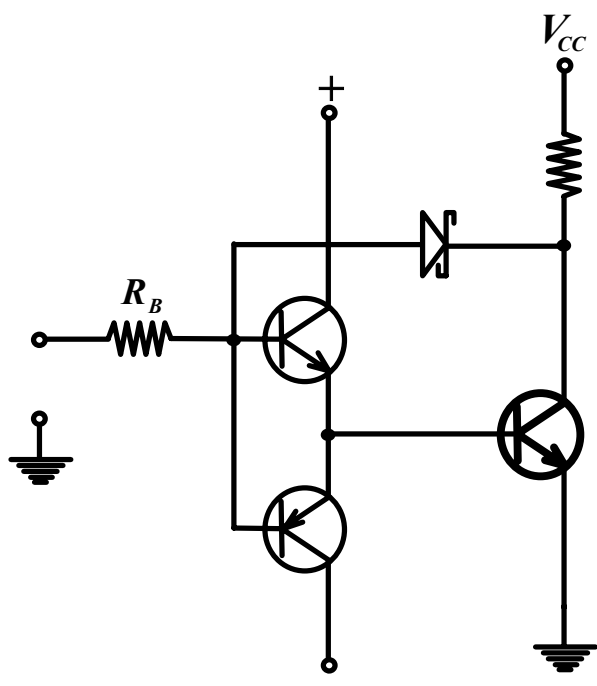

pilotaggio di MOSFET

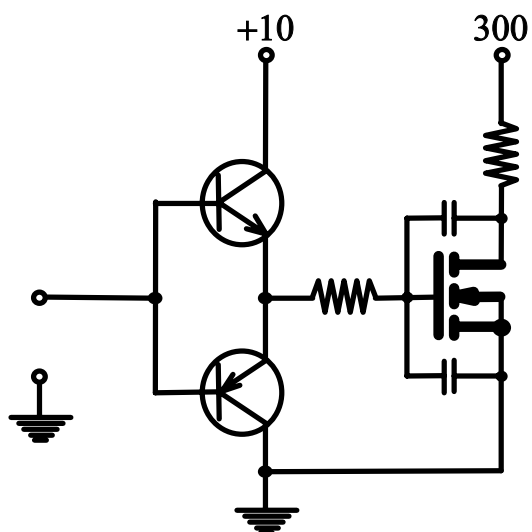

Esempio numerico

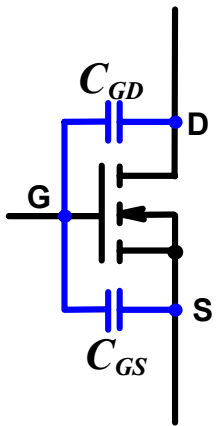

$$C_{GD} = 50 \text{ pF}$$

$$C_{GS} = 500 \text{ pF}$$

$$\Delta Q = C_{GS} \Delta V_{GS} + C_{GD} \Delta V_{DG}$$

$$= 500 \cdot 10^{-12} \cdot 10 + 50 \cdot 10^{-12} \cdot 290 \cong$$

$$\cong 20 \cdot 10^{-9} = 20 \text{ nC}$$

$$I = \frac{\Delta Q}{\Delta t} = \frac{20 \cdot 10^{-9}}{100 \cdot 10^{-9}} = \mathbf{200 \text{ mA}}$$

IGBT (Insulated Gate Bipolar Transistor)

Caratteristiche principali: V_{CE} bassa, pilotaggio di MOS, lento ON → OFF